

LV Detuning Reactors



General technical parameters

Standards	IEC EN 60076-6, IEC EN 61558-2-20
Rated Voltage	400 - 800 V / 50 Hz
Rated Power	1 - 100 kvar
Inductance Tolerance	-5 / +5 %
Detuning Factor	5,67 %, 7 %, 14 %
Resonance Frequency	210 Hz, 189 Hz, 134 Hz
Temperature Class	F (155 °C)
Ambient Temperature	40 °C
Statistical Life Expectancy	> 200 000 hours
Protection Degree	IP 00
Insulation (winding - core)	3 kV
Max. Relative Humidity	95 %
Max. Altitude	4 000 m
Cooling	Natural Air or Forced
Design	Three phase, iron core with multi air gap
Winding Material	Copper (TKC), Aluminium (TKA)
Impregnant	Polyester (epoxy) resin
Safety Device	Thermal switch (TKA-130 °C, TKC-90 °C)
Terminals	Terminal block, Cable lug, Al bar

Application

Frequent use of power electronic devices with nonlinear loads leads to harmonic distortion in electrical system. This nonsinusoidal load causes increase of effective current of power capacitor and other components of the system as well as the possibility of capacitor resonance with other inductive loads. Finally it may lead to problems or even failures in the installation. The solution is to use detuning (filtering) reactors, which creates a series resonant circuit with power capacitors. This detuned system prevents the installation from resonance effect and also acts as a filter for higher harmonic content. Usually there is recommended to use detuning reactors for the total voltage distortion THD-U higher than 3 %.

Construction

Detuning reactors are produced from high grade, low loss transformer sheets, with winding either from copper wire or aluminium band. Iron core is designed with multi air gap to meet high current linearity and low thermal losses. They are impregnated with high quality epoxy resin to ensure good insulation, low noise and long lifetime. Reactors are equipped with thermal protection to prevent overheating. Reactors with lower rated power are designed with copper wire and outlets via terminal block or cable lug. Higher power rated reactors are produced from aluminium band with outlets as aluminium bars (copper outlets are possible on request).

Reactor power designation

Reactor type designation is always according to power of matching capacitor Q_c .

Q_c - Rated power of the capacitor

Q_{Lc} - Rated power of the detuned system (capacitor + reactor)

Power		Capacitance		Inductance	Current	Weight	Dimensions
Q_c (kvar)	Q_{Lc} (kvar)	C_N (Δ) (μ F)	Type	L_N (mH)	I_N (A)	m (kg)	WxDxH (mm)
$U_N = 400$ V	$U_c = 440$ V	$p = 7\%$ (189Hz)	$I_{lin} \geq 1,6 I_N$				
50	44,4	274	TKA1-50-189/400/440	0,86	64,1	23	250 x 185 x 215
56,2	50	308	TKA1-56,2-189/400/440	0,77	72,0	23	250 x 185 x 215

Standard types

(other voltages, power and 60 Hz on request)

$p = 7\%$ $U_N = 400$ V $U_c = 440$ V $I_{lin} \geq 1,6 I_N$

Q_c (kvar)	Q_{Lc} (kvar)	C_N (Δ) (μ F)	Type	L_N (mH)	I_N (A)	m (kg)	WxDxH (mm)	Design
5	4,4	27,4	TKC1-05-189/400/440	8,64	6,4	4,5	150 x 90 x 150	Cu / 1
6,25	5,6	34,3	TKC1-06,25-189/400/440	6,90	8,0	4,5	150 x 90 x 150	Cu / 1
10	8,9	54,8	TKC1-10-189/400/440	4,32	12,8	7,5	180 x 100 x 180	Cu / 1
12,5	11	68,5	TKC1-12,5-189/400/440	3,46	16,0	8,5	180 x 110 x 180	Cu / 1
15	13,3	82,2	TKC1-15-189/400/440	2,88	19,2	11	180 x 120 x 180	Cu / 1
20	17,8	110	TKC1-20-189/400/440	2,17	25,6	11	180 x 120 x 180	Cu / 1
25	22,2	137	TKC1-25-189/400/440	1,73	32,1	15	180 x 135 x 180	Cu / 1
25	22,2	137	TKA1-25-189/400/440	1,73	32,1	13	235 x 150 x 160	Al / 2
2 x 25	2 x 22,2	2 x 137	TKA1-2x25-189/400/440	1,73	32,1	25	235 x 150 x 290	Al / 2
28,1	25	154	TKA1-28,2-189/400/440	1,53	36,0	13	235 x 150 x 160	Al / 2
2 x 28,1	2 x 25	2 x 154	TKA1-2x28,1-189/400/440	1,53	36,0	25	235 x 150 x 290	Al / 2
30	26,7	164	TKA1-30-189/400/440	1,44	38,5	17	255 x 160 x 195	Al / 2
40	35,5	219	TKA1-40-189/400/440	1,08	51,3	18	255 x 160 x 195	Al / 2
50	44,4	274	TKA1-50-189/400/440	0,86	64,1	23	250 x 185 x 215	Al / 2
2 x 50	2 x 44,4	2 x 274	TKA1-2x50-189/400/440	0,86	64,1	40	250 x 185 x 380	Al / 2
56,2	50	308	TKA1-56,2-189/400/440	0,77	72,0	23	250 x 185 x 215	Al / 2
2 x 56,2	2 x 50	2 x 308	TKA1-2x56,2-189/400/440	0,77	72,0	40	250 x 185 x 380	Al / 2
75	66,7	411	TKA1-75-189/400/440	0,58	96,1	31	305 x 190 x 255	Al / 2
100	88,9	548	TKA1-100-189/400/440	0,43	128,0	34	305 x 190 x 255	Al / 2

p = 7 % U_N = 400 V U_C = 525 V I_{lin} ≥ 1,6 I_N

Q _c (kvar)	Q _{Lc} (kvar)	C _N (Δ) (μF)	Type	L _N (mH)	I _N (A)	m (kg)	WxDxH (mm)	Design
12,5	7,8	48,1	TKC1-12,5-189/400/525	4,91	11,3	8,5	180 x 100 x 180	Cu / 1
25	15,6	96,2	TKC1-25-189/400/525	2,46	22,5	11	180 x 120 x 180	Cu / 1
50	31,2	192	TKA1-50-189/400/525	1,23	45,0	22	250 x 185 x 215	Al / 2
75	46,8	289	TKA1-75-189/400/525	0,82	67,6	23	250 x 185 x 215	Al / 2

p = 5,67 % U_N = 400 V U_C = 440 V I_{lin} ≥ 2,0 I_N

Q _c (kvar)	Q _{Lc} (kvar)	C _N (Δ) (μF)	Type	L _N (mH)	I _N (A)	m (kg)	WxDxH (mm)	Design
6,25	5,5	34,3	TKC1-6,25-210/400/440	5,60	7,9	4,5	150 x 90 x 155	Cu / 1
12,5	11,0	68,5	TKC1-12,5-210/400/440	2,80	15,8	8,5	180 x 110 x 180	v
25	21,9	137	TKA1-25-210/400/440	1,40	31,6	13	235 x 150 x 160	Al / 2
50	43,8	274	TKA1-50-210/400/440	0,70	63,2	23	250 x 185 x 215	Al / 2

p = 14 % U_N = 400 V U_C = 480 V I_{lin} ≥ 1,38 I_N

Q _c (kvar)	Q _{Lc} (kvar)	C _N (Δ) (μF)	Type	L _N (mH)	I _N (A)	m (kg)	WxDxH (mm)	Design
12,5	10,1	57,5	TKC1-12,5-134/400/480	8,21	14,6	14	180 x 135 x 180	Cu / 1
25	20,2	115	TKA1-25-134/400/480	4,11	29,1	25	285 x 180 x 215	Al / 2
30	24,2	138	TKA1-30-134/400/480	3,42	35,0	25	285 x 180 x 215	Al / 2
50	40,4	230	TKA1-50-134/400/480	2,05	58,3	37	335 x 190 x 255	Al / 2
60	48,5	276	TKA1-60-134/400/480	1,71	69,9	37	335 x 190 x 255	Al / 2

p = 14 % U_N = 400 V U_C = 525 V I_{lin} ≥ 1,38 I_N

Q _c (kvar)	Q _{Lc} (kvar)	C _N (Δ) (μF)	Type	L _N (mH)	I _N (A)	m (kg)	WxDxH (mm)	Design
12,5	8,4	48,2	TKC1-12,5-134/400/525	9,77	12,2	14	180 x 135 x 180	Cu / 1
25	16,8	96,4	TKC1-25-134/400/525	4,88	24,3	18	225 x 135 x 180	Cu / 1
37,5	25,3	144	TKA1-37,5-134/400/525	3,27	36,5	24	285 x 180 x 215	Al / 2
50	33,7	193	TKA1-50-134/400/525	2,46	48,7	27	300 x 185 x 215	Al / 2
75	50,6	289	TKA1-75-134/400/525	1,64	73,1	37	335 x 190 x 255	Al / 2

Terminal	1	2	3
Type	Terminal Black	Al bar	Cable lug*

* optional, on request

Design Cu/1

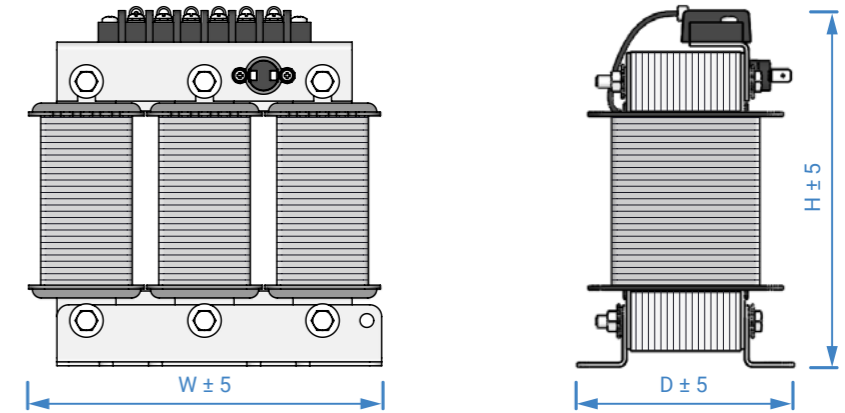

Design Al/2

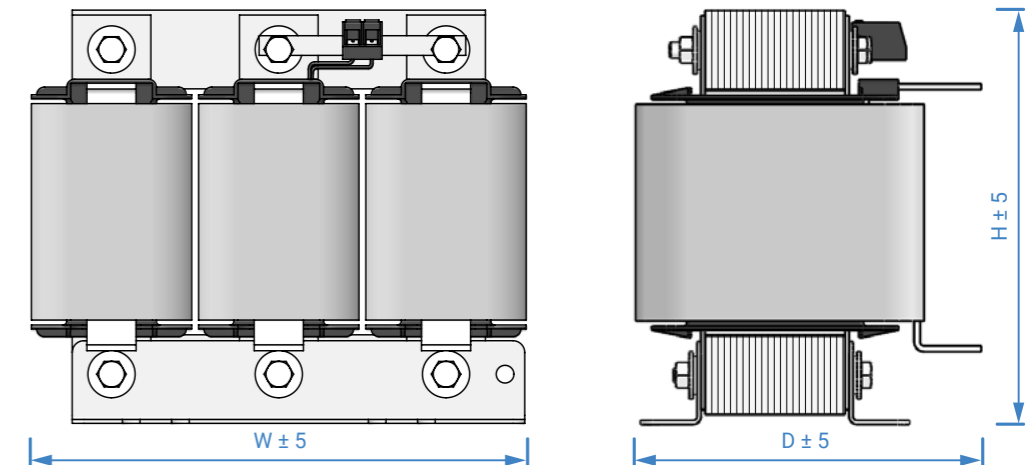

Design Al/2 - double

