



# CRYSTALLINE SILICON PV MODULE INSTALLATION GUIDE

**THE POWER OF ASTRONERGY**



**ASTRONERGY**

A **CHNT** COMPANY

# CRYSTALLINE SILICON PV MODULE INSTALLATION GUIDE

## **1. Introduction**

- 1.1 *Purpose*
- 1.2 *Limitation of Liability*

## **2. Safety**

- 2.1 *General Safety*
- 2.2 *Installation Safety*

## **3. Mechanical Installation**

- 3.1 *Installation Condition*
- 3.2 *Installation Methods*

## **4. Electrical Installation**

- 4.1 *Installation Condition*
- 4.2 *Grounding*

## **5. Maintenance and Disposal**

# 1. Introduction

## 1.1 Purpose

This document provides detailed instructions and valuable safety information regarding the installation, electrical connection, and maintenance of the following ASTRONERGY Crystalline Photovoltaic modules:

CHSM5409M	CHSM5612M	CHSM5612M (BL)	CHSM6608M
CHSM6610M	CHSM6610M (BL)	CHSM6610P (BL)	CHSM6610P
CHSM6612P	CHSM6610Q	CHSM6612Q	

All instructions and mechanical and electrical requirements should be read and understood before attempting installation. The installer should conform to all safety precautions in this guide when installing the module. Keep this guide in a safe place for further reference.

## 1.2 Limitation of Liability

Because the use of this manual and the conditions or methods of installation, operation, use and maintenance of photovoltaic (PV) products are beyond Astronergy’s control, Astronergy does not accept responsibility and expressly disclaims liability for loss, damage, or expense arising out of or in any way connected with such installation, operation, use or maintenance. Astronergy reserves the right to change the manual without prior notice.

# 2. Safety

## 2.1 General Safety

- 2.1.1 Consult and follow local codes and other applicable laws concerning required permitting as well as installation & inspection requirements, rules, and regulations.
- 2.1.2 PV modules should be installed and maintained by qualified personnel.
- 2.1.3 Use the same performance modules within a given series.
- 2.1.4 Follow all safety precautions of all components used in the system.
- 2.1.5 Do not shade portions of the PV module surface from the sun for a long period of time. The shaded cell may become hot (hot spot phenomenon), which can result in solder joints peeling off.
- 2.1.6 Do not clean the glass surface with chemicals.
- 2.1.7 Do not drop the PV module or drop objects onto the PV module.
- 2.1.8 Do not concentrate sunlight on the modules or panels.
- 2.1.9 Do not attempt to disassemble the modules, and do not remove any attached components from the modules.
- 2.1.10 Do not scratch or hit at the back sheet, the glass, the terminal box. Do not pull the cables or touch them with bare hands.
- 2.1.11 Do not drill holes in the frame or scratch the insulating coating of the frame.

- 2.1.12 Keep the PV module packed in the carton until installation.
- 2.1.13 Do not use modules near equipment or in places where flammable gases may be generated.
- 2.2 Installation Safety**
- 2.2.1 Wear protective head gear, insulating gloves, safety shoes, and insulated tools when installing the modules.
- 2.2.2 Do not install the modules in rain, snow, or otherwise wet or windy conditions.
- 2.2.3 Completely cover the PV module surface with an opaque material during PV module installation and wiring to prevent accidental charge buildup.
- 2.2.4 Plug in connectors tightly when working on wiring.
- 2.2.5 Due to the risk of electrical shock, do not perform any work if the terminals of PV module are wet.
- 2.2.6 Do not touch the terminal box and the end of output cables (connectors) with bare hands.
- 2.2.7 Do not unplug the connector under load.
- 2.2.8 Do not work alone.
- 2.2.9 Wear a safety belt if working far above the ground.
- 2.2.10 Do not wear metallic jewelry, which can cause electric shock, while installing or troubleshooting the PV system.
- 2.2.11 Follow the safety regulations for any and all other system components, including wires, connectors, charging regulators, batteries, inverters, etc.
- 2.2.12 Do not expose wires to direct sunlight. Use UV-resistant cabling.
- 2.2.13 Do not damage the surrounding PV modules or mounting structure when replacing a PV module.
- 2.2.14 Do not change any PV module components (diode, junction box, plug connectors, etc.).
- 2.2.15 Maximum reverse current is 13.5A for module with 5 inch cells and 20.25A for module with 6 inch cells. Use a blocking diode and fuse in the combiner box are recommended for reverse current protection when more than three strings are connected in parallel.
- 2.2.16 The solar modules are recommended to be installed over a fireproof and insulating roof covering when installed on a roof.

### 3. Mechanical Installation

#### 3.1 Installation Conditions

- 3.1.1 Environment temperature: -40 to 85 °C
- 3.1.2 Operating temperature: -40 to 85 °C
- 3.1.3 Mechanical load on panels (e.g., from wind or snow): less than 5400 Pa
- 3.1.4 Tilt Angle selection: The installation should be facing north in the southern hemisphere and facing south in the northern hemisphere.
- 3.1.5 To maintain the modules' Class C fire rating, the fire class of the roof and building materials should be higher than Class C.

#### 3.2 Installation Methods

##### 3.2.1 Bolting

All modules must be securely fastened with at least 4 bolts (Fig. (a) and (b)). For maximum security against strong winds or heavy snow falls, suggestion for all of the mounting holes should be used.

Especially, this mounting method isn't suitable for the 45mm frame thickness of CHSM6612P and 35mm frame thickness of CHSM6610P product series.

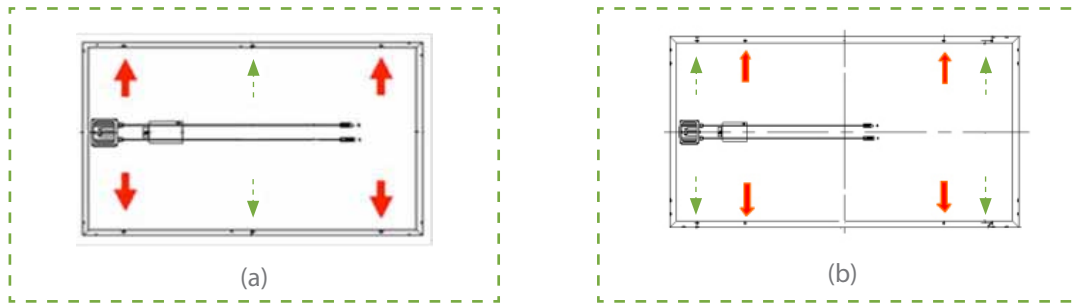

*Remark: As for above diagram, the solid red arrows indicate primary bolt positions; dashed blue arrows indicate positions where bolts can be added for additional support.*

Bolts are inserted as described in the process below (Fig. (c) ).

1. Place the module on the supporting bars underneath.
2. Insert four stainless-steel bolts (M6) through the holes (7x11.5mm) in the frame according to the Fig. (a) & (b). For maximum security against strong winds and heavy snow, all available mounting holes should be used.
3. Secure each bolt to the frame with 2 stainless-steel washers, one on each side of the mounting structure; and screw on either a stainless-steel spring washer or a toothed lock washer. Finally, secure with a stainless steel nut (M6).
4. The torque for tightening the nut and bolts recommended 13Nm when the property class of bolts and screws is Class 8.8.

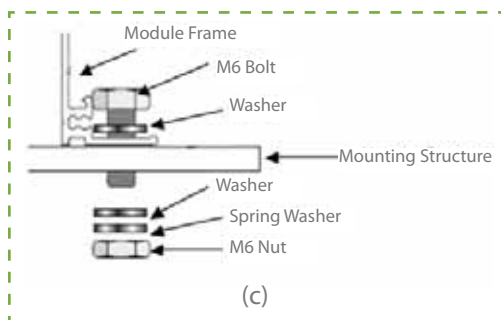

### 3.2.2 Clamping

Modules can be laid either across the supporting bars (Fig. (d) ) or parallel to them (Fig. (e) & (f) ).

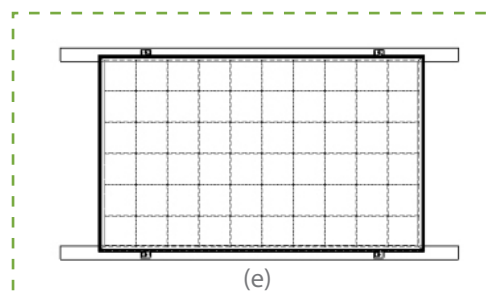
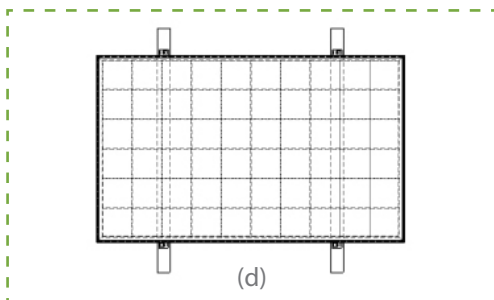

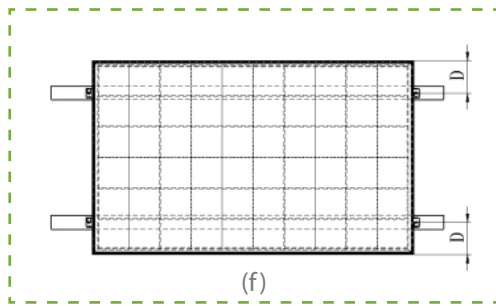

Remark: Illustrations of the three different methods for clamping modules onto the frame with aluminum clamps.

Each aluminum mounting clamp comes with an M8 bolt, a plain washer, a spring washer, and an M8 nut. To fasten the module:

1. Place the module on the two supporting bars (not provided). The bars should be made with stainless material or treated with an anti-corrosion process (e.g., anodic oxidation treatment).
2. The bar's top surface contacted with module frame should come with grooves compatible with an M8 bolt.
3. If the bars do not come with grooves, holes of a suitable diameter may need to be drilled to allow bolts to be attached to the bars at the same locations as mentioned before.
4. Secure each clamp by attaching plain washer, spring washer, and nut, in that order.
5. Both of close-ups of Fig. (g) indicate the middle clamps and Fig. (h) indicate the side clamps for your reference. The dimensions for the middle clamps are  $a \geq 40$  mm,  $b \geq 26$  mm,  $c = 8$  mm,  $d \geq 28$  mm, and  $\varnothing = 9$  mm. The torque for tightening the nut and bolts recommended 28Nm when the property class of bolts and screws is Class 8.8.

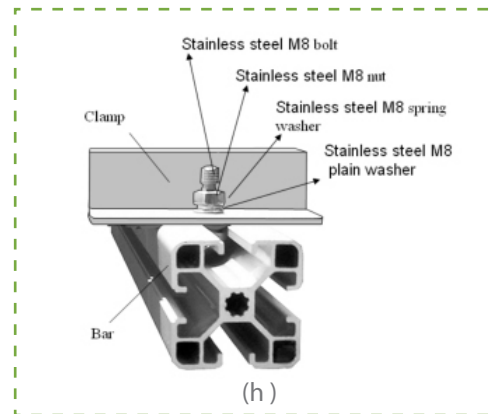
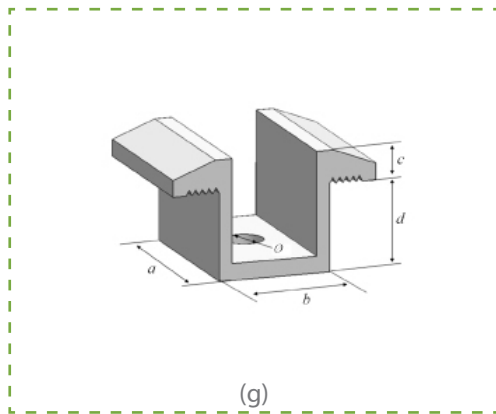

6. Especially for Fig. (d) mounting method, slide bolts through groove on the supporting bars next to the locations where the 4 clamps are to be fastened. The module may be clamped only in the permitted clamping area as on the long edge of the frame. For exact locations on the frame refer to Fig. (i) in conjunction with table 1 below.

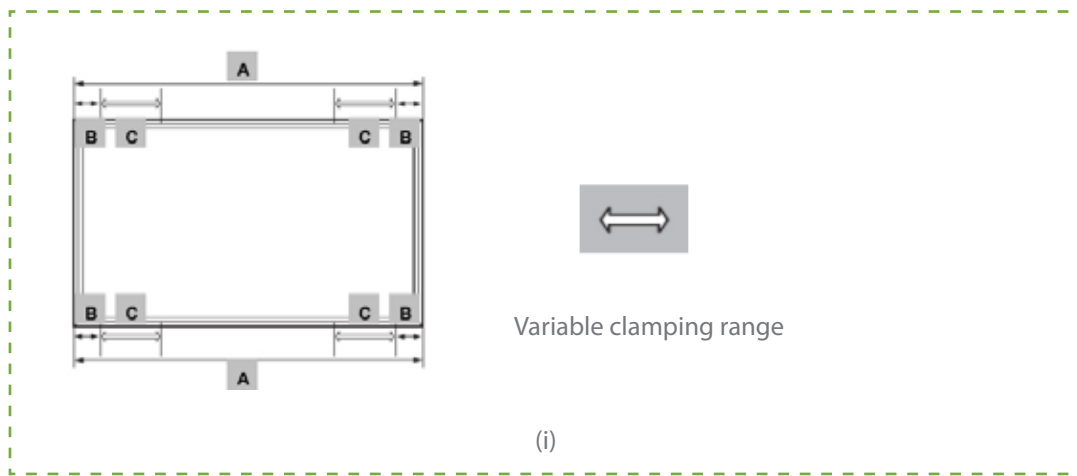

For exact dimensions for a given module series, please see the following table 1. Use in conjunction with Fig. (i) to determine permitted clamping locations for a given module series for clamping with clamps:

Module Series	Dimension	A	B	C
CHSM5409M	1200*554*35	1200	50	250
CHSM5612M/(BL)	1580*808*35	1580	200	200
CHSM6610P	1652*994*35	1652	200	210
CHSM6608M	1336*994*40	1336	50	280
CHSM6610M/(BL)	1652*994*40	1652	50	360
CHSM6610P/(BL)/Q	1652*994*40	1652	50	360
CHSM5612M	1580*808*45	1580	50	350
CHSM6610M	1652*994*45	1652	50	360
CHSM6610P	1652*994*45	1652	50	360
CHSM6612P	1956*994*45	1956	480	20
CHSM6612P/Q	1956*994*50	1956	60	440

7. Especially for Fig. (e) mounting method, the modules may be mounted using clamps designed for solar modules refer to Fig. (g), the modules must be supported along the length of the long edge, and should overlap the array rail by 10mm – 14mm

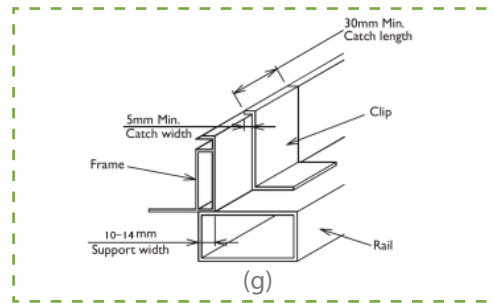

8. Especially for Fig. (f) mounting method which is not suitable for 35mm frame thickness of CHSM6610P and 45mm frame thickness of CHSM6612P product series, clamp positions are important – the clamp centerlines refer to mark “D” which must be between 50mm and 200mm from the end of the module.

## 4. Electrical Installation and Grounding

### 4.1 Installation

- 4.1.1 The electrical characteristics are within  $\pm 10$  percent of the indicated values of  $I_{sc}$ ,  $V_{oc}$  and  $P_{mp}$  under test conditions (irradiance of  $100\text{mW}/\text{cm}^2$ , AM1.5 spectrum, and a cell temperature of  $25^\circ\text{C}$ ).
- 4.1.2 The maximum system voltage for all module series is 600 V for North American Market and 1000V for European Market.
- 4.1.3 Connect quantity of modules that match the voltage specifications of the inverters used in system. Modules must not be connected together to create a voltage higher than the permitted maximum system voltage under the worst local temperature conditions.
- 4.1.4 Under normal conditions, a photovoltaic module is likely to experience conditions that produce more current and/or voltage than reported at standard test conditions. Accordingly, the values of  $I_{sc}$  and  $V_{oc}$  marked on this module should be multiplied by a factor of 1.25 when determining component voltage ratings, conductor ampacities, fuse sizes, and size of controls connected to the PV output.
- 4.1.5 Refer to Section 690-8 of the National Electrical Code for an additional multiplying factor of 125 percent (80 percent derating) which may be applicable.
- 4.1.6 Each module (or series-connected string of modules) shall be provided with the maximum series fuse, specified as 10 A for the 5 inch cell module series and 15A for the 6 inch cell module series.
- 4.1.7 Use a special solar cable and plugs for installing the PV system and make sure that all connections are safe and tight. The cable should be  $4\text{ mm}^2$  (12AWG), and able to withstand the maximum possible system open-circuit voltage.
- 4.1.8 Bypass diodes are included in module junction boxes to avoid decreased module performance in the event of shade or shelter. Please check the relevant product datasheet for the specific diodes of J-box.



## 4.2 Grounding

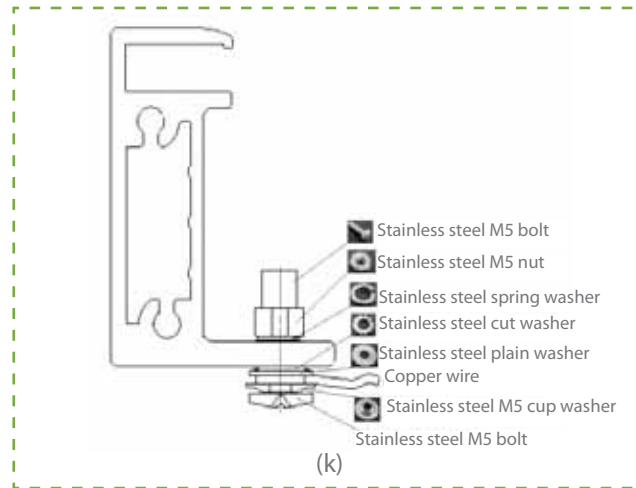

*Grounding the aluminum frame with copper wire*

- 4.2.1 Use the marked 5.5 mm grounding holes (5.5mm) to ground the anodized frame. Use an M5 nut, two M5 cut washers, an M5 plain washer, an M5 spring washer, and an M5 bolt and a copper wire. All nuts, bolts, and washers are type M5 and should be made of stainless steel (Fig. (k)).
- 4.2.2 Put the bolt through the cup washer and wrap the copper wire around the bolt. (Note that the copper wire cannot be attached directly to the aluminum.)
- 4.2.3 Put the bolt through the cut washer and then through the hole in the aluminum frame.
- 4.2.4 Add the spring washer and nut on the other side of the bolt and tighten to secure all parts. The tightening torque should be  $210 \pm 20 \text{ N}\cdot\text{cm}$ .
- 4.2.5 Approve the use of UL-467 approved bonding and grounding devices, including Burndy (formerly Wiley Electronics) Washer Electrical Equipment Bonding (WEEB) and similar devices, such as barbed washers, that meet the requirements of UL-467 as suitable for electrical bonding and grounding PV modules to PV mounting systems.

## 5. Maintenance

- 5.1 Regularly carry out a visual inspection for dirt, dust, bird dropping, leaves, and other detritus covering the modules.
- 5.2 If there is a build-up of dirt or dust on the module surface, wash the module with clean water and a gentle implement (a sponge). Never use chemicals on the surface of the module.
- 5.3 If snow is present, a soft-bristled brush with soft bristles may be used to clean the surface of the modules.
- 5.4 Regular electrical and mechanical inspection by a licensed professional will keep the system safe and operating at maximum efficiency.



## CORPORATE HEADQUARTERS

Chint Solar (ZheJiang) Co., Ltd.  
1335 Bin'an Road, Binjiang District  
Hangzhou, Zhejiang Province, 310053  
China  
Tel: + 86 571 5603 1888  
Fax: + 86 571 5603 2383

## MANUFACTURING PLANTS

Hangzhou, Shanghai & Jiuquan

## SUBSIDIARIES

### Spain

Chint Solar Hispania S.L.  
Paseo de Gracia, 78, 2-2A  
08008 Barcelona,  
Spain  
Tel: + 34 9346 73778  
Fax: + 34 9346 73789

### Germany

Astronergy GmbH  
Karlstr. 8  
88212 Ravensburg,  
Germany  
Tel: + 49 (0)751 295096-10  
Fax: + 49 (0)751 295096-39

### North America

Astronergy Solar, Inc.  
Suite 1125, 795 Folsom Street,  
San Francisco, CA 94107  
USA  
Tel: +1 650 392 2777

### Korea

Astronergy Solar Korea  
5th FL. Cowell Bldg, 66-1,  
Banpo-Dong, Seocho-Gu,  
Korea  
Tel: + 82 (0)2 2226 3911  
Fax: + 82 (0)2 2226 3910

### Thailand

Astronergy Solar Korea (Thailand) Co., Ltd.  
184/88 Forum Tower 18FL  
Ratchadapisek Rd., Huay-Kwang,  
Bangkok 10320  
Thailand  
Tel: + 662 645 4155  
Fax: + 662 245 3185

### Japan