

# Thermal Solutions



Get Familiar With Linkwell  
Products Online:  
[www.linkwell.org](http://www.linkwell.org)



Innovation-Quality-Global

## INTRODUCTION

We are mainly dealing with low voltage electrical products for switchgear board and automation industry, such as panel filter and fans, panel heaters, thermostats and hygostats , wiring accessories, etc. Through our decades' efforts and developments now LINKWELL become a group company with several factories by entirely holding or partly holding , not only self production but also few trading, in order to provide one- stop-solution for panel builders.

Our main markets are European countries, Americans and China market. You can find us in more than 60 countries all over the world, well-known with very good reputation in the market for the sake of our good quality and competitive prices, kind and prompt services to clients.

LINKWELL ELECTRIC policy is to offer a full support to Clients:

- pre-after sales assistance
- customized products
- fast delivery
- monitoring of customers' satisfaction

Rather than a supplier, LINKWELL ELECTRIC aims to be a Client's industrial PARTNER!

Our company always pays special attention to protecting the benefits of clients' so that both the clients and our company are able to gain the maximum benefits from the relations between us.

We warmly look forward to establishing, reinforcing and expanding long term fruitful relationship with the reliable clients all over the world.

Let's get busy and pull together to create a better future!



# CONTENTS



LK33/ FF / FK55 series filter *01-31*



Cabinet top ventilator *32-36*



Air-cooled Conditioner *37-40*



Thermostat Hygostat *41-55*



Heater *56-67*



Multiplane fan *68-75*



Lamp for Cabinet *76-88*



# Cabinet Ventilation

# LK 3321 series filter



EMC Fan and filter

Fan and filter	Fan and filter	Exit filter	Installing section
LK 3321 ...	LK 3321.230	LK 3321.300	LK 3321 ...

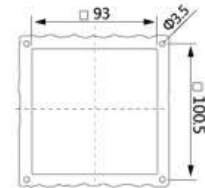
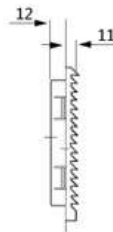
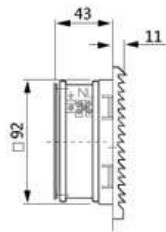

Model No. fan-and-filter unit LK	3321.230	3321.115	3321.024
Model No. fan-and-filter unit EMC	3321.230-EMC	3321.115-EMC	3321.024-EMC
Rated operating voltage V, Hz	230, 50/60	115, 50/60	24 (DC)
Air throughput, unimpeded air flow	25/35 m <sup>3</sup> /h		35 m <sup>3</sup> /h
Air throughput with outlet filter including standard filter mat	1 x LK 3321.300: 20/25 m <sup>3</sup> /h		
Axial fan	Self-starting shaded pole motor		DC motor
Rated current max.	0.08 A	0.14 A	0.18 A
Power	18/14 W		4.3 W
Noise level	37/41 dB(A)		41 dB(A)
Temperature range	-30 to +70°C		
Colour	RAL 7035, different colours on request		
Protection category to EN 60 529/09.2000	IP 54 standard IP 56 when using a hose-proof hood		
Model No. outlet filter LK / EMC	3321.300 / 3321.300-EMC		
Design	made of injection-moulded thermoplastic, self-extinguishing UL 94 V0		



EMC Fan and filter

Fan and filter	Fan and filter	Exit filter	Installing section
LK 3322...	LK 3322.230	LK 3322.300	LK 3322...

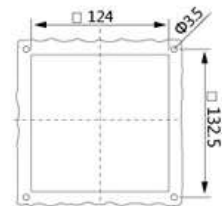
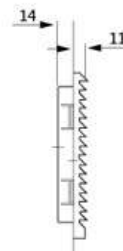
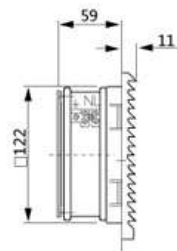

Model No. fan-and-filter unit LK	3322.230	3322.115	3322.024
Model No. fan-and-filter unit EMC	3322.230-EMC	3322.115-EMC	3322.024-EMC
Rated operating voltage V, Hz	230, 50/60	115, 50/60	24 (DC)
Air throughput, unimpeded air flow	65/85 m <sup>3</sup> /h		85 m <sup>3</sup> /h
Air throughput with outlet filter including standard filter mat	1 x LK 3322.300: 55/70 m <sup>3</sup> /h		
Axial fan	Self-starting shaded pole motor		DC motor
Rated current max.	0.12/0.10 A	0.24/0.20 A	0.35 A
Power	19.0/14.0 W		7.7 W
Noise level	36/40 dB(A)		40 dB(A)
Temperature range	-30 to +70°C		
Colour	RAL 7035, different colours on request		
Protection category to EN 60 529/09.2000	IP 54 standard IP 56 when using a hose-proof hood		
Model No. outlet filter LK / EMC	3322.300 / 3322.300-EMC		
Design	made of injection-moulded thermoplastic, self-extinguishing UL 94 V0		

# LK 3323 series filter

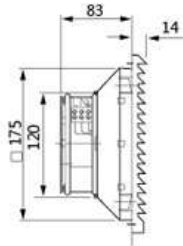
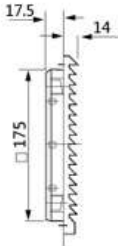
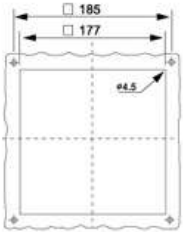

EMC Fan and filter

Fan and filter	Fan and filter	Exit filter	Installing section
LK 3323...	LK 3323.230	LK 3323.300	LK 3323...
			

Model No. fan-and-filter unit LK	3323.230	3323.115	3323.024
Model No. fan-and-filter unit EMC	3323.230-EMC	3323.115-EMC	3323.024-EMC
Rated operating voltage V, Hz	230, 50/60	115, 50/60	24 (DC)
Air throughput, unimpeded air flow	105/126 m <sup>3</sup> /h		105 m <sup>3</sup> /h
Air throughput with outlet filter including standard filter mat	1 x LK 3323.300: 71/82 m <sup>3</sup> /h 2 x LK 3323.300: 85/98 m <sup>3</sup> /h		
Axial fan	Self-starting shaded pole motor		DC motor
Rated current max.	0.12/0.10 A	0.24/0.20 A	0.35 A
Power	19.0/14.0 W		7.7 W
Noise level	36/40 dB(A)		40 dB(A)
Temperature range	-30 to +70°C		
Colour	RAL 7035, different colours on request		
Protection category to EN 60 529/09.2000	IP 54 standard IP 56 when using a hose-proof hood		
Model No. outlet filter LK / EMC	3323.300 / 3323.300-EMC		
Design	made of injection-moulded thermoplastic, self-extinguishing UL 94 V0		



EMC Fan and filter

Fan and filter	Fan and filter	Exit filter	Installing section
LK 3324...	LK 3324.230	LK 3324.300	LK 3324...

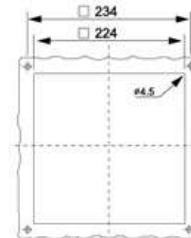
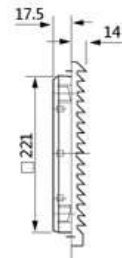
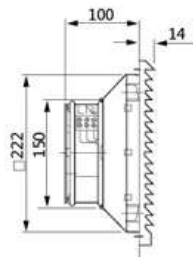

Model No. fan-and-filter unit LK	3324.230	3324.115	3324.024
Model No. fan-and-filter unit EMC	3324.230-EMC	3324.115-EMC	3324.024-EMC
Rated operating voltage V, Hz	230, 50/60	115, 50/60	24 (DC)
Air throughput, unimpeded air flow	240/220 m <sup>3</sup> /h		220 m <sup>3</sup> /h
Air throughput with outlet filter including standard filter mat	1 x LK 3324.300: 145/110 m <sup>3</sup> /h 2 x LK 3324.300: 185/155 m <sup>3</sup> /h		
Axial fan	Self-starting shaded pole motor		DC motor
Rated current max.	0.48/0.46 A	0.26/0.24 A	0.58 A
Power	41.0/38.0 W		14 W
Noise level	48/50 dB(A)		50 dB(A)
Temperature range	-30 to +70°C		
Colour	RAL 7035, different colours on request		
Protection category to EN 60 529/09.2000	IP 54 standard IP 56 when using a hose-proof hood		
Model No. outlet filter LK / EMC	3324.300 / 3324.300-EMC		
Design	made of injection-moulded thermoplastic, self-extinguishing UL 94 V0		

# LK 3325 series filter



EMC Fan and filter

Fan and filter	Fan and filter	Exit filter	Installing section
LK 3325...	LK 3325.230	LK 3325.300	LK 3325...

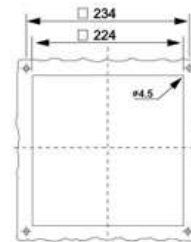
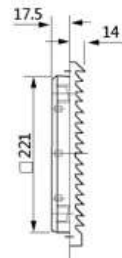
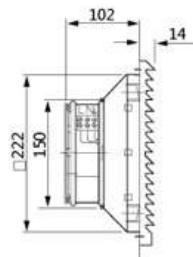

Model No. fan-and-filter unit LK	3325.230	3325.115
Model No. fan-and-filter unit EMC	3325.230-EMC	3325.115-EMC
Rated operating voltage V, Hz	230, 50/60	115, 50/60
Air throughput, unimpeded air flow	230/265 m <sup>3</sup> /h	
Air throughput with outlet filter including standard filter mat	1 x LK 3325.300: 170/205 m <sup>3</sup> /h 2 x LK 3325.300: 200/230 m <sup>3</sup> /h	
Axial fan	Self-starting shaded pole motor	
Rated current max.	0.25/0.20 A	0.52/0.43 A
Power	37.0/33.0 W	
Noise level	46/50 dB(A)	
Temperature range	-30 to +70°C	
Colour	RAL 7035, different colours on request	
Protection category to EN 60 529/09.2000	IP 54 standard, IP 55 when using an additional fine filter mat, IP 56 when using a hose-proof hood	
Model No. outlet filter LK / EMC	3325.300 / 3325.300-EMC	
Design	made of injection-moulded thermoplastic, self-extinguishing UL 94 V0	



EMC Fan and filter

Fan and filter	Fan and filter	Exit filter	Installing section
LK 3326...	LK 3326.230	LK 3326.300	LK 3326...

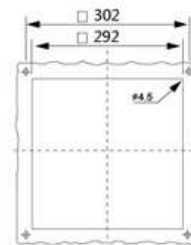
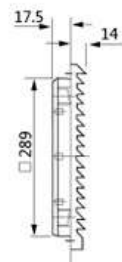
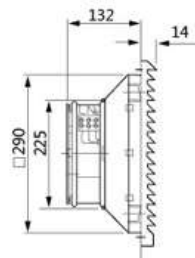
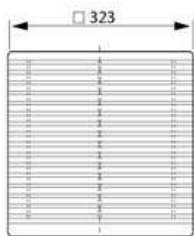

Model No. fan-and-filter unit LK	3326.230	3326.115
Model No. fan-and-filter unit EMC	3326.230-EMC	3326.115-EMC
Rated operating voltage V, Hz	230, 50/60	115, 50/60
Air throughput, unimpeded air flow	580/700 m <sup>3</sup> /h	
Air throughput with outlet filter including standard filter mat	1 x LK 3326.300: 380/410 m <sup>3</sup> /h 2 x LK 3326.300: 460/515 m <sup>3</sup> /h	
Axial fan	Capacitor operated	
Rated current max.	0.34/0.30 A	0.64/0.60 A
Power	75.0/65.0 W	
Noise level	55/57 dB(A)	
Temperature range	-30 to +70°C	
Colour	RAL 7035, different colours on request	
Protection category to EN 60 529/09.2000	IP 54 standard IP 56 when using a hose-proof hood	
Model No. outlet filter LK / EMC	3326.300 / 3326.300-EMC	
Design	made of injection-moulded thermoplastic, self-extinguishing UL 94 V0	

# LK 3327 series filter

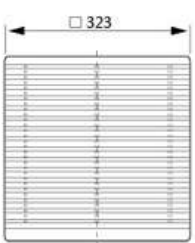
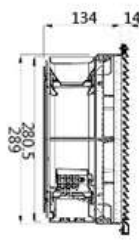
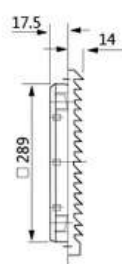
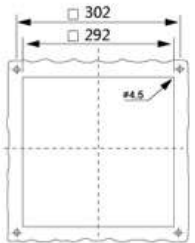

Cabinet Ventilation

Fan and filter	Fan and filter	Exit filter	Installing section
LK 3327...	LK 3327.230	LK 3327.300	LK 3327...
			

Model No. fan-and-filter unit LK	3327.230	3327.115
Model No. fan-and-filter unit EMC	3327.230-EMC	3327.115-EMC
Rated operating voltage V, Hz	230, 50/60	115, 50/60
Air throughput, unimpeded air flow	1150/1350 m <sup>3</sup> /h	
Air throughput with outlet filter including standard filter mat	1 x LK 3327.300: 750/950 m <sup>3</sup> /h	
Axial fan	Capacitor operated	
Rated current max.	0.62/0.48 A	1.2/1.1 A
Power	140.0/105.0 W	136.0/110.0 W
Noise level	63/65 dB(A)	
Temperature range	-30 to +70°C	
Colour	RAL 7035, different colours on request	
Protection category to EN 60 529/09.2000	IP 54 standard, IP 55 when using an additional fine filter mat, IP 56 when using a hose-proof hood	
Model No. outlet filter LK / EMC	3327.300 / 3327.300-EMC	
Design	made of injection-moulded thermoplastic, self-extinguishing UL 94 V0	



Cooling capacity performance curves

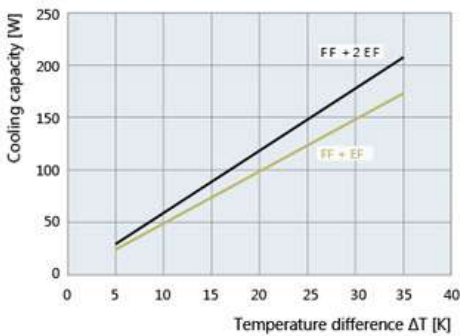

Characteristics of static pressure

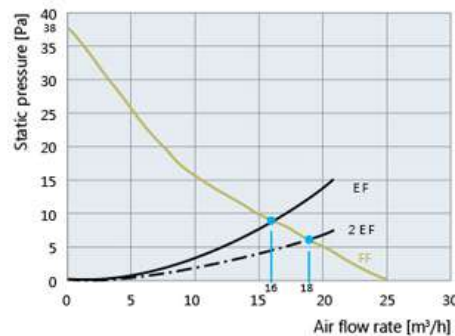

Dimensions

mm	FF109		EF 109
	AC	DC	
X	109	109	109
Y	109	109	109
Z1	4	4	4
Z2	62	62	19
A <sup>1</sup>	92	92	92
B <sup>1</sup>	92	92	92

<sup>1</sup> for material thickness up to 2mm  
+1 mm for thickness of material > 2 mm ≤ 3 mm

Data		FF 109				
Model	Unit	FF109.230	FF109.115	FF109.012	FF109.024	FF109.048
Rated voltage ±10%	V	AC 50/60			DC	
Unimpeded air flow	m³/h	25/29				
Combined air volume	m³/h	16/18				
Power	W	9/7	15/14	2.4	2.4	2.6
Current	A	0.08/0.07	0.15/0.13	0.2	0.1	0.05
Noise level	dB(A)	33/33			33	
Type of connection		Terminal row				
Protection level		NEMA type 12 - standard filter				
Filtration efficiency	%	88				
Filter pad performance level		G3				
Duty cycle	%	100				
Bearing type		sleeve bearing		ball bearing		
Service life	h	52,500	55,000	70,000		
Temperature range	°C/°F	-40...+70/-40...+131				
Design		made of injection-moulded thermoplastic, self-extinguishing UL 94 VO				
Colour		RAL 7035, different colours on request				

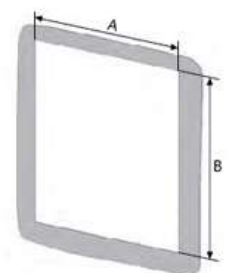

# FF145 series filter



Cooling capacity performance curves

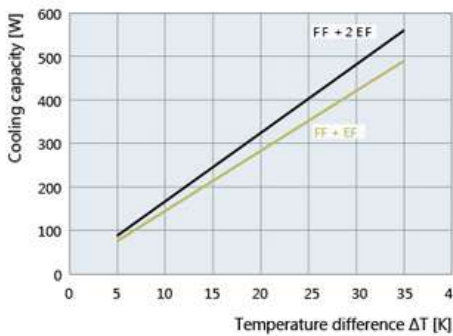

Characteristics of static pressure

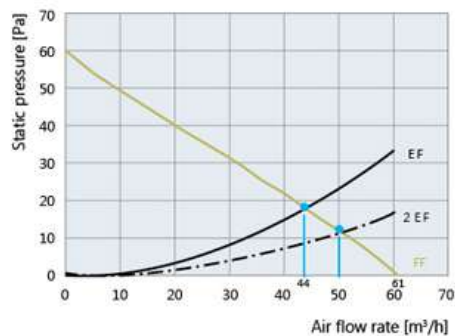

Dimensions

mm	FF145		EF 145
	AC	DC	
X	145	145	145
Y	145	145	145
Z1	5	5	5
Z2	70	70	27
A <sup>1</sup>	125	125	125
B <sup>1</sup>	125	125	125

<sup>1</sup> for material thickness up to 2mm  
+1 mm for thickness of material > 2 mm ≤ 3 mm

Data		FF 145				
Model	Unit	FF145.230	FF145.115	FF145.012	FF145.024	FF145.048
Rated voltage ±10%	V	AC 50/60			DC	
Unimpeded air flow	m³/h	IP54-61/70 IP55-56/64				
Combined air volume	m³/h	IP54-44/52 IP55-40/46				
Power	W	19/14	18/15	5	5	5
Current	A	0.12/0.10	0.24/0.20	0.42	0.21	0.1
Noise level	dB(A)	44/44			44	
Type of connection		Terminal row				
Protection level		NEMA type 12 - standard filter				
Filtration efficiency	%	88				
Filter pad performance level		G3				
Duty cycle	%	100				
Bearing type		sleeve bearing			ball bearing	
Service life	h	37,500	40,000	62,500		
Temperature range	°C/°F	-40...+70/-40...+131				
Design		made of injection-moulded thermoplastic, self-extinguishing UL 94 VO				
Colour		RAL 7035, different colours on request				

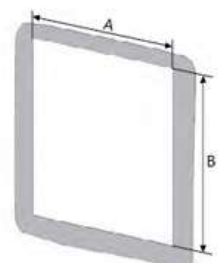



Cooling capacity performance curves

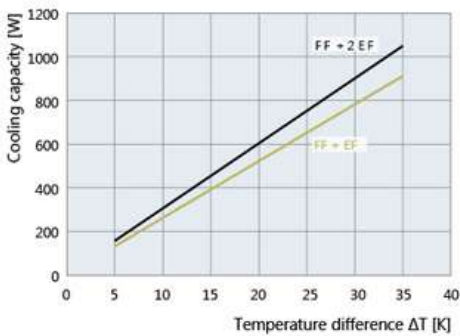

Characteristics of static pressure

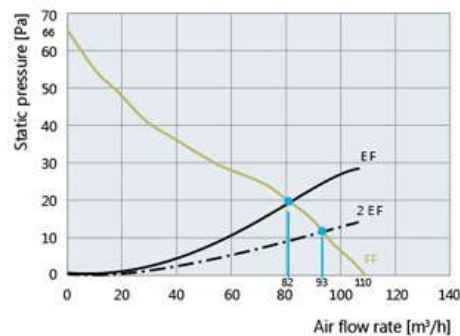

Dimensions

mm	FF 202		EF 202
	AC	DC	
X	202	202	202
Y	202	202	202
Z1	6.5	6.5	6.5
Z2	87	87	30
A <sup>1</sup>	177	177	177
B <sup>1</sup>	177	177	177

<sup>1</sup> for material thickness up to 2mm  
+1 mm for thickness of material > 2 mm ≤ 3 mm

Data		FF 202				
Model	Unit	FF202.230	FF202.115	FF202.012	FF202.024	FF202.048
Rated voltage ±10%	V	AC 50/60			DC	
Unimpeded air flow	m <sup>3</sup> /h	IP54-110/125		IP55-100/110		
Combined air volume	m <sup>3</sup> /h	IP54-82/93		IP55-55/64		
Power	W	19/18	20/20	5	5	5
Current	A	0.12/0.10	0.24/0.20	0.42	0.21	0.1
Noise level	dB(A)	40/40			40	
Type of connection		Terminal row				
Protection level		NEMA type 12 - standard filter				
Filtration efficiency	%	88				
Filter pad performance level		G3				
Duty cycle	%	100				
Bearing type		sleeve bearing		ball bearing		
Service life	h	37,500	40,000	62,500		
Temperature range	°C/°F	-40...+70/-40...+131				
Design		made of injection-moulded thermoplastic, self-extinguishing UL 94 VO				
Colour		RAL 7035, different colours on request				



# FF252-P series filter



Cooling capacity performance curves

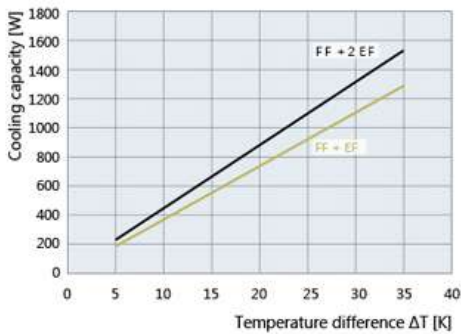

Characteristics of static pressure

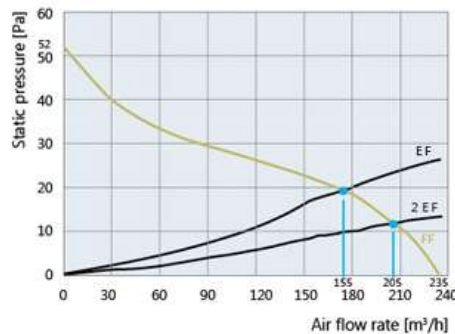

Dimensions

mm	FF 252-P		EF 252
	AC	DC	
X	252	252	252
Y	252	252	252
Z1	6.5	6.5	6.5
Z2	111	111	33
A <sup>1</sup>	223	223	223
B <sup>1</sup>	223	223	223

<sup>1</sup> for material thickness up to 2mm  
+1 mm for thickness of material > 2 mm ≤ 3 mm

Data		FF 252-P				
Model	Unit	FF252-P.230	FF252-P.115	FF252-P.012	FF252-P.024	FF252-P.048
Rated voltage ±10%	V	AC 50/60			DC	
Unimpeded air flow	m³/h	IP54-225/260		IP55-205/235		
Combined air volume	m³/h	IP54-202/235		IP55-155/185		
Power	W	36/30	36/30	6	4.7	4.6
Current	A	0.25/0.21	0.49/0.45	0.5	0.2	0.1
Noise level	dB(A)	40/43			40	
Type of connection		Terminal row				
Protection level		NEMA type 12 - standard filter				
Filtration efficiency	%	88				
Filter pad performance level		G3				
Duty cycle	%	100				
Bearing type		ball bearing				
Service life	h	40,000	42,500	57,500	70,000	
Temperature range	°C/°F	-40...+55/-40...+131				
Design		made of injection-moulded thermoplastic, self-extinguishing UL 94 VO				
Colour		RAL 7035, different colours on request				



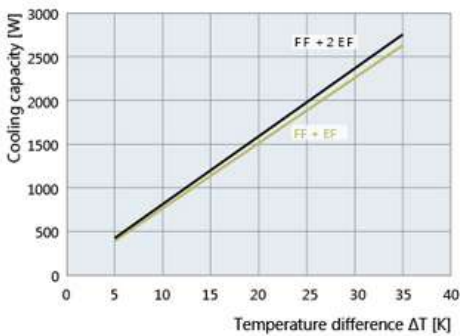
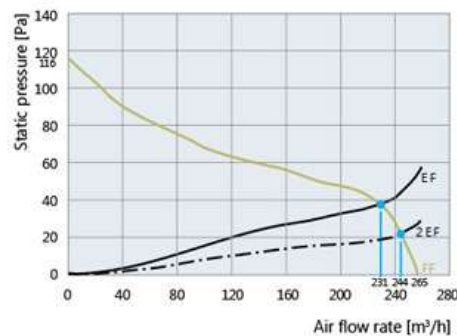

**Cooling capacity performance curves**

**Characteristics of static pressure**

**Dimensions**

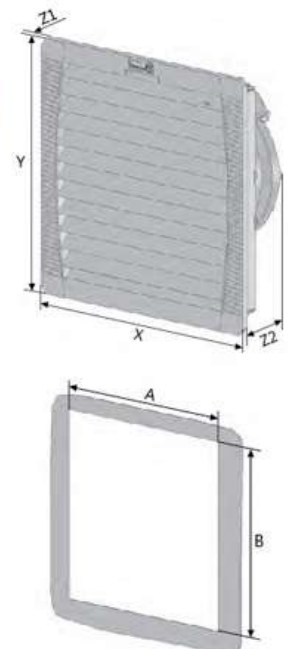
mm	FF252-M	EF 252
X	252	252
Y	252	252
Z1	6.5	6.5
Z2	114	33
A <sup>1</sup>	223	223
B <sup>1</sup>	223	223

<sup>1</sup> for material thickness up to 2mm  
+1 mm for thickness of material > 2 mm ≤ 3 mm

Data		FF 252-M		
Model	Unit	FF252-M.400	FF252-M.230	FF252-M.115
Rated voltage ±10%	V	AC 50/60		
Unimpeded air flow	m <sup>3</sup> /h	IP54-256/292 IP55-233/265		
Combined air volume	m <sup>3</sup> /h	IP54-231/265 IP55-180/207		
Power	W	42/37	37/33	40/40
Current	A	0.16/0.14	0.25/0.20	0.52/0.43
Noise level	dB(A)	42/46		
Type of connection		Terminal row		
Protection level		NEMA type 12 - standard filter		
Filtration efficiency	%	88		
Filter pad performance level		G3		
Duty cycle	%	100		
Bearing type		ball bearing		
Service life	h	40,000		
Temperature range	°C/°F	-40...+70/-40...+131		
Design		made of injection-moulded thermoplastic, self-extinguishing UL 94 VO		
Colour		RAL 7035, different colours on request		



# FF320 series filter



Cooling capacity performance curves

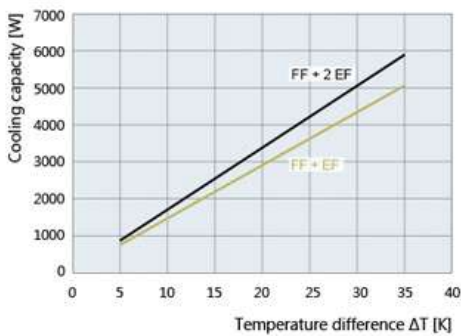

Characteristics of static pressure

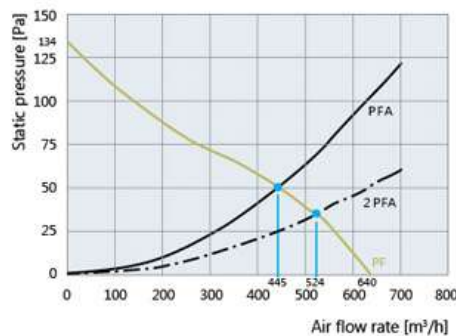

Dimensions

mm	FF 320	EF 320
X	320	320
Y	320	320
Z1	7	7
Z2	162	36
A <sup>1</sup>	291	291
B <sup>1</sup>	291	291

<sup>1</sup> for material thickness up to 2mm  
+1 mm for thickness of material > 2 mm ≤ 3 mm

Data		FF 320	
Model	Unit	FF320.230	FF320.115
Rated voltage ±10%	V	AC 50/60 Hz	
Unimpeded air flow	m³/h	IP54-580/700	IP55-550/670
Combined air volume	m³/h	IP54-490/550	IP55-470/530
Power	W	75/65	
Current	A	0.59/0.47	1.2/1.1
Noise level	dB(A)	59/62	
Type of connection		Terminal row	
Protection level		NEMA type 12 - standard filter	
Filtration efficiency	%	91	
Filter pad performance level		G4	
Duty cycle	%	100	
Bearing type		ball bearing	
Service life	h	40,000	
Temperature range	°C/°F	-40... +70/-40... +131	
Design		made of injection-moulded thermoplastic, self-extinguishing UL 94 VO	
Colour		RAL 7035, different colours on request	

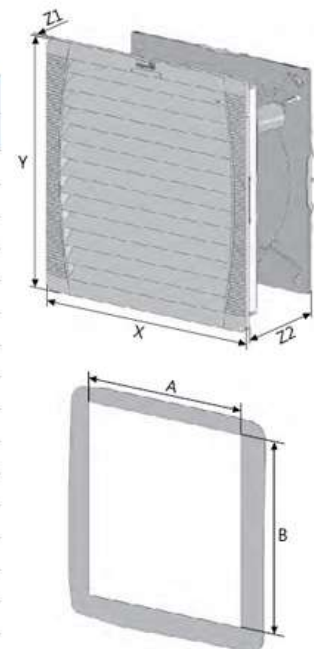

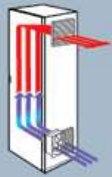

Cooling capacity performance curves

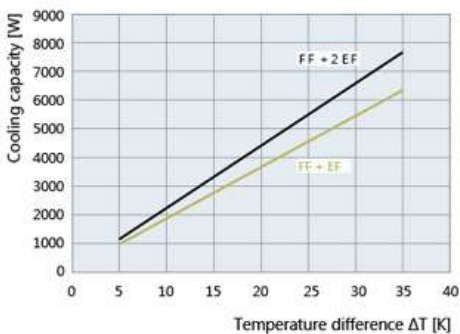

Characteristics of static pressure

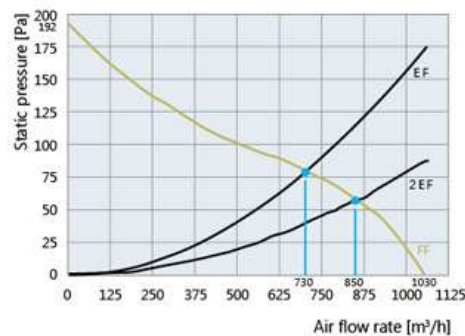

Dimensions

mm	FF 320-D	EF 320
X	320	320
Y	320	320
Z1	7	7
Z2	162	36
A <sup>1</sup>	291	291
B <sup>1</sup>	291	291

<sup>1</sup> for material thickness up to 2mm  
+1 mm for thickness of material > 2 mm ≤ 3 mm

Data		FF 320-D	
Model	Unit	FF320-D.230	FF320-D.115
Rated voltage ±10%	V	AC 50/60 Hz	
Unimpeded air flow	m <sup>3</sup> /h	IP54-1150/1350	IP55-950/1150
Combined air volume	m <sup>3</sup> /h	IP54-800/1030	IP55-750/950
Power	W	135/104	149/110
Current	A	0.59/0.47	1.2/1.1
Noise level	dB(A)	63/65	
Type of connection		Terminal row	
Protection level		NEMA type 12 - standard filter	
Filtration efficiency	%	91	
Filter pad performance level		G4	
Duty cycle	%	100	
Bearing type		ball bearing	
Service life	h	40,000	
Temperature range	°C/°F	-40...+70/-40...+131	
Design		made of injection-moulded thermoplastic, self-extinguishing UL 94 VO	
Colour		RAL 7035, different colours on request	

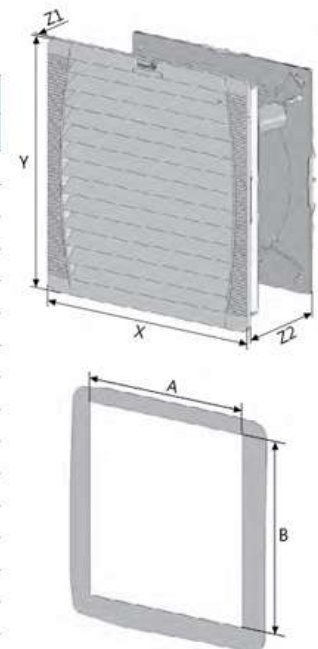

# FF5000 series filter



Cooling capacity performance curves

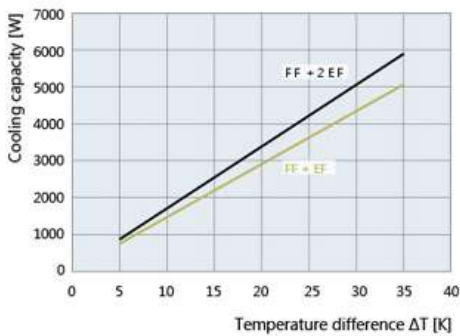

Characteristics of static pressure

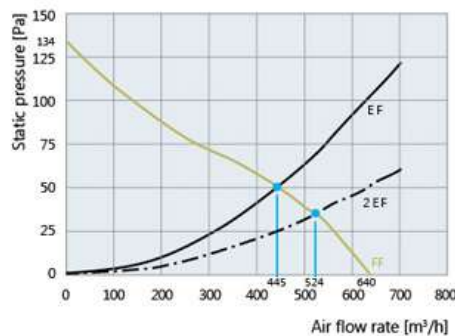

Dimensions

mm	FF 5000	EF 320
X	320	320
Y	320	320
Z1	7	7
Z2	125	36
A <sup>1</sup>	291	291
B <sup>1</sup>	291	291

<sup>1</sup> for material thickness up to 2mm  
+1 mm for thickness of material > 2 mm ≤ 3 mm

Data		FF 5000	
Model	Unit	FF5000.230	FF5000.115
Rated voltage ±10%	V	AC 50/60 Hz	
Unimpeded air flow	m³/h	IP54-550/650	IP55-460/515
Combined air volume	m³/h	IP54-490/540	IP55-425/475
Power	W	71/62	
Current	A	0.34/0.30	0.64/0.62
Noise level	dB(A)	54/52	
Type of connection		Terminal row	
Protection level		NEMA type 12 - standard filter	
Filtration efficiency	%	91	
Filter pad performance level		G4	
Duty cycle	%	100	
Bearing type		ball bearing	
Service life	h	40,000	
Temperature range	°C/°F	-40...+70/-40...+131	
Design		made of injection-moulded thermoplastic, self-extinguishing UL 94 VO	
Colour		RAL 7035, different colours on request	

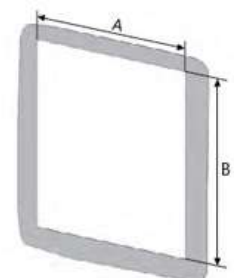
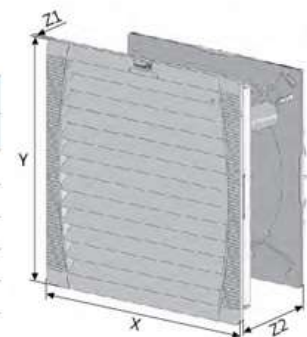



Cooling capacity performance curves

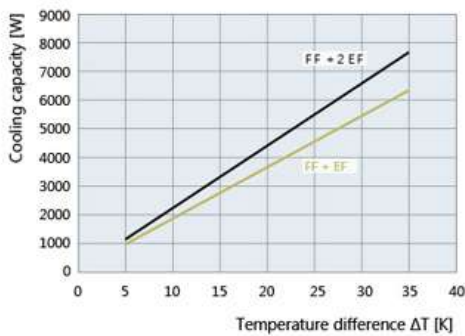

Characteristics of static pressure

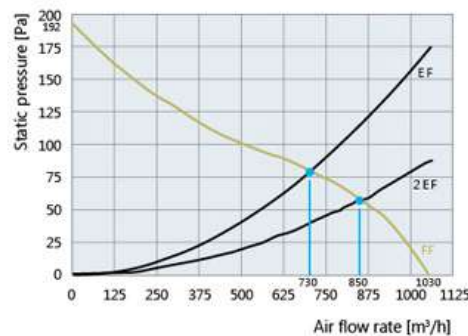

Dimensions

mm	FF 7000	EF 320
X	320	320
Y	320	320
Z1	7	7
Z2	127	36
A <sup>1</sup>	291	291
B <sup>1</sup>	291	291

<sup>1</sup> for material thickness up to 2mm  
+1 mm for thickness of material > 2 mm ≤ 3 mm

Data		FF 7000		
Model	Unit	FF7000.400	FF7000.230	FF7000.115
Rated voltage ±10%	V	AC 50/60 Hz		
Unimpeded air flow	m³/h	IP54-1050/1250 IP55-900/1100		
Combined air volume	m³/h	IP54-700/930 IP55-650/850		
Power	W	155/120	135/104	149/110
Current	A	0.26/0.25	0.59/0.47	1.2/1.1
Noise level	dB(A)	63/64		
Type of connection		Terminal row		
Protection level		NEMA type 12 - standard filter		
Filtration efficiency	%	91		
Filter pad performance level		G4		
Duty cycle	%	100		
Bearing type		ball bearing		
Service life	h	40,000		
Temperature range	°C/°F	-40...+70/-40...+131		
Design		made of injection-moulded thermoplastic, self-extinguishing UL 94 VO		
Colour		RAL 7035, different colours on request		

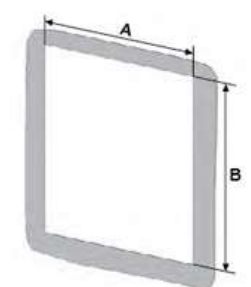

# FK5521 series filter

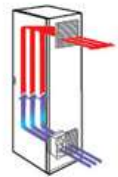

Cabinet Ventilation

Fan and filter	Fan and filter	Exit filter	Installing section
FK 5521...	FK 5521.230	FK 5521.300	FK 5521...

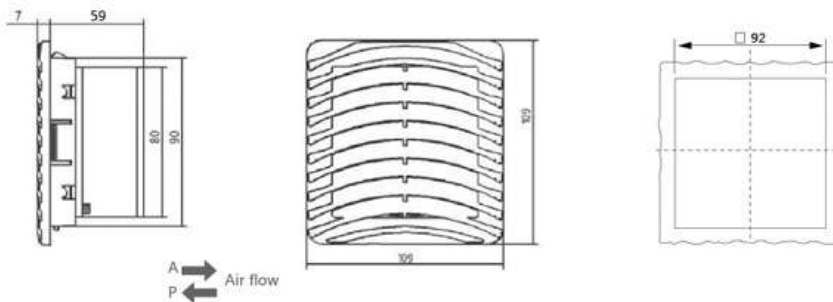

CODE		Exit filter	Fan and filter	Fan and filter	Fan and filter
TYPE	M.U	FK5521.300	FK5521.230	FK5521.115	FK5521.024
Voltage/phase/frequency	V-ph-Hz		220-240/1/50-60	110-120/1/50-60	24DC
Height/Width/Depth	mm	109×109×21	109×109×59	109×109×59	109×109×59
Power/Current	W/A		13/0.08-0.07	15/0.15-0.13	9.6/0.4
Temperature limits	°C		-30/+70	-30/+70	-30/+70
Protection degree	IP	54	54	54	54
Noise level	dB(A)		35	30	30
Air flow	m <sup>3</sup> /h		35	35	35
Air flow (+FK5521.300)	m <sup>3</sup> /h		24/27	24/27	24/27
Air flow direction			A/P	A/P	A/P

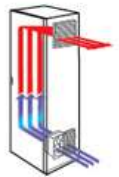

Fan and filter	Fan and filter	Exit filter	Installing section
FK 5522 ...	FK 5522.230	FK 5522.300	FK 5522...

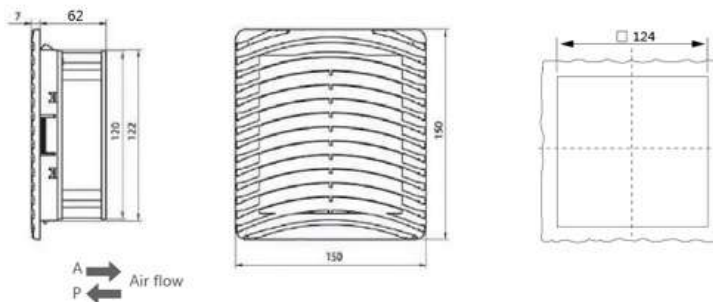

CODE		Exit filter	Fan and filter	Fan and filter	Fan and filter
TYPE	M.U	FK5522.300	FK5522.230	FK5522.115	FK5522.024
Voltage/Phase/Frequency	V-ph-Hz		230-1-50/60	115/1/50-60	24DC
Height/Width/Depth	mm	150×150×21	150×150×62	150×150×62	150×150×62
Power/Current	W/A		30-22/0.14-0.1	26-22/0.24-0.21	7.2/0.43
Temperature limits	°C		-30/+70	-30/+70	-30/+70
Protection degree	IP	54	54	54	54
Noise level	dB(A)		45	45	45
Air flow	m³/h		67	67	67
Air flow (+FK5522.300)	m³/h		50/58	50/58	50/58
Air flow direction			A/P	A/P	A/P

# FK5523 series filter

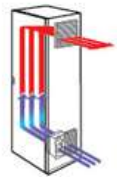

Cabinet Ventilation

Fan and filter	Fan and filter	Exit filter	Installing section
FK 5523...	FK 5523.230	FK 5523.300	FK 5523...

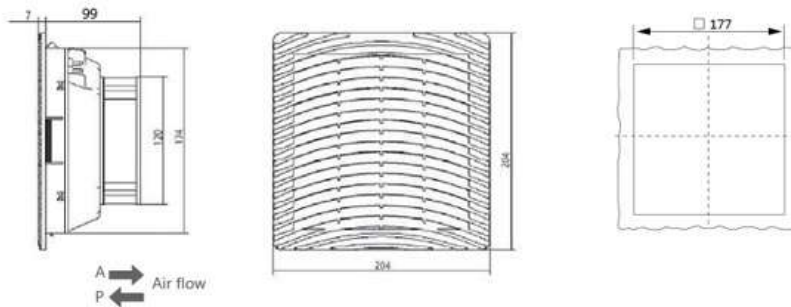

CODE		Exit filter	Fan and filter	Fan and filter	Fan and filter
TYPE	M.U	FK5523.300	FK5523.230	FK5523.115	FK5523.024
Voltage/Phase/Frequency	V-ph-Hz		230-1-50/1/60	115/1/50-60	24DC
Height/Width/Depth	mm	204×204×25	204×204×99	204×204×99	204×204×99
Power/Current	W/A		30-22/0.14-0.1	26-22/0.24-0.21	7.2/0.43
Temperature limits	°C		-30/+70	-30/+70	-30/+70
Protection degree	IP	54	54	54	54
Noise level	dB(A)		45	45	45
Air flow	m <sup>3</sup> /h		105/120	105/120	105/120
Air flow (+FK5523.300)	m <sup>3</sup> /h		85/100	85/100	85/100
Air flow direction			A/P	A/P	A/P



Fan and filter	Fan and filter	Exit filter	Installing section
FK 5524 ...	FK 5524.230	FK 5524.300	FK 5524...

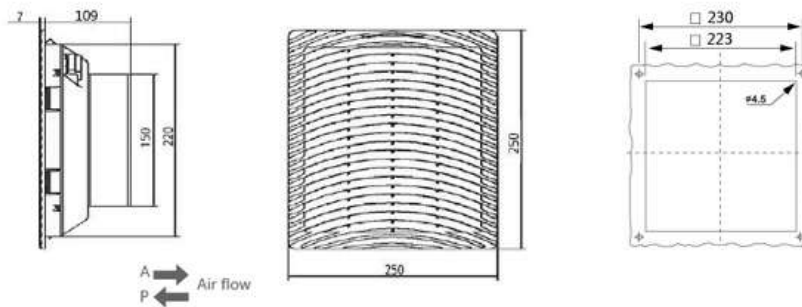

CODE		Exit filter	Fan and filter	Fan and filter	Fan and filter
TYPE	M.U	FK5524.300	FK5524.230	FK5524.115	FK5524.024
Voltage/Phase/Frequency	V-ph-Hz		230-1-50/60	115-1-50/60	24DC
Height/Width/Depth	mm	250×250×25	250×250×109	250×250×109	250×250×109
Power/Current	W/A		41-38/0.48-0.46	41-38/0.26-0.24	14/0.58
Temperature limits	°C		-30/+70	-30/+70	-30/+70
Protection degree	IP	54	54	54	54
Noise level	dB(A)		48/50	48/50	50
Air flow	m <sup>3</sup> /h		240/220	240/220	220
Air flow (+FK5524.300)	m <sup>3</sup> /h		120/150	120/150	120/150
Air flow direction			A/P	A/P	A/P

# FK5525 series filter

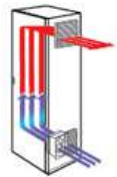

Cabinet Ventilation

Fan and filter	Fan and filter	Exit filter	Installing section
FK 5525...	FK 5525.230	FK 5525.300	FK 5525...

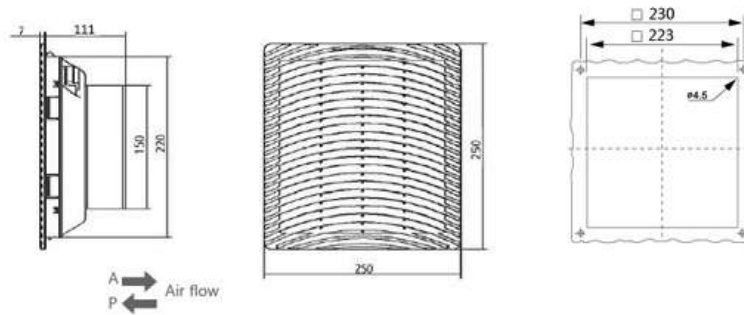

CODE		Exit filter	Fan and filter	Fan and filter
TYPE	M.U	FK5525.300	FK5525.230	FK5525.115
Voltage/Phase/Frequency	V-ph-Hz		230-1-50/60	115-1-50/60
Height/Width/Depth	mm	250×250×25	250×250×111	250×250×111
Power/Current	W/A		59-46/0.33-0.28	47-42/0.50
Temperature limits	°C		-30/+70	-30/+70
Protection degree	IP	54	54	54
Noise level	dB(A)		52	52
Air flow	m <sup>3</sup> /h		230/265	230/265
Air flow (+FK5525.300)	m <sup>3</sup> /h		170/230	170/230
Air flow direction			A/P	A/P



Fan and filter	Fan and filter	Exit filter	Installing section
FK 5526 ...	FK 5526.230	FK 5526.300	FK 5526...

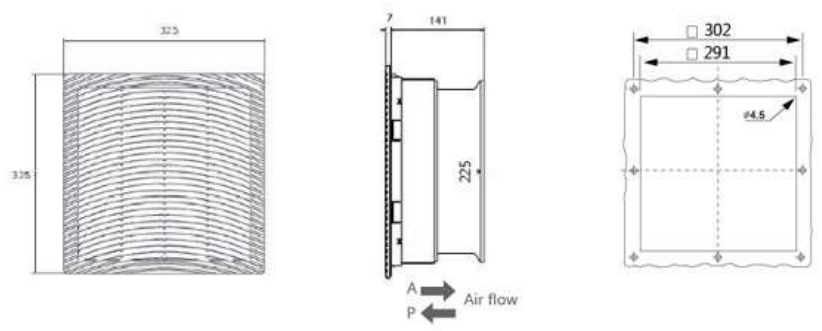

CODE		Exit filter	Fan and filter	Fan and filter
TYPE	M.U	FK5526.300	FK5526.230	FK5526.115
Voltage/Phase/Frequency	V-ph-Hz		230-1-50/1/60	115/1/50-60
Height/Width/Depth	mm	325×325×25	325×325×141.5	325×325×141.5
Power/Current	W/A		63/0.29	61/0.61
Temperature limits	°C		-30/+70	-30/+70
Protection degree	IP	54	54	54
Noise level	dB(A)		59	59
Air flow	m³/h		550/600	550/600
Air flow (+FK5526.300)	m³/h		360/490	360/490
Air flow direction			A	A

# FK5527 series filter

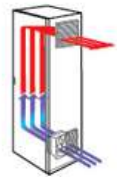

Cabinet Ventilation

Fan and filter	Fan and filter	Exit filter	Installing section
FK 5527...	FK 5527.230	FK 5527.300	FK 5527...

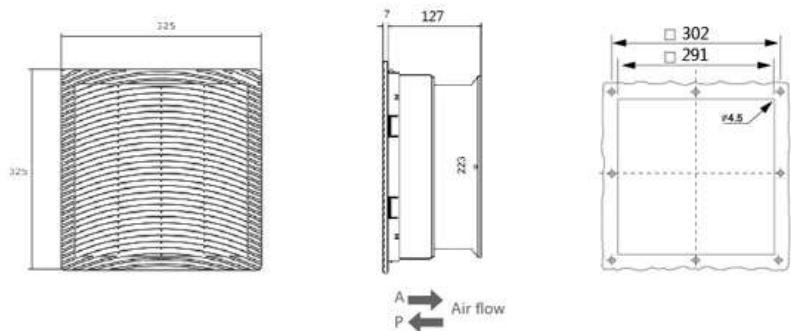

CODE		Exit filter	Fan and filter	Fan and filter
TYPE	M.U	FK5527.300	FK5527.230	FK5527.115
Voltage/Phase/Frequency	V-ph-Hz		230-1-50/1/60	115/1/50-60
Height/Width/Depth	mm	325×325×25	325×325×127	325×325×127
Power/Current	W/A		50/0.26	50/0.46
Temperature limits	°C		-30/+70	-30/+70
Protection degree	IP	54	54	54
Noise level	dB(A)		59	59
Air flow	m³/h		650/800	650/800
Air flow (+FK5527.300)	m³/h		500/600	500/600
Air flow direction			A	A

 Fan and filter  
FK 5528 ...

 Fan and filter  
FK 5528.230

 Exit filter  
FK 5528.300

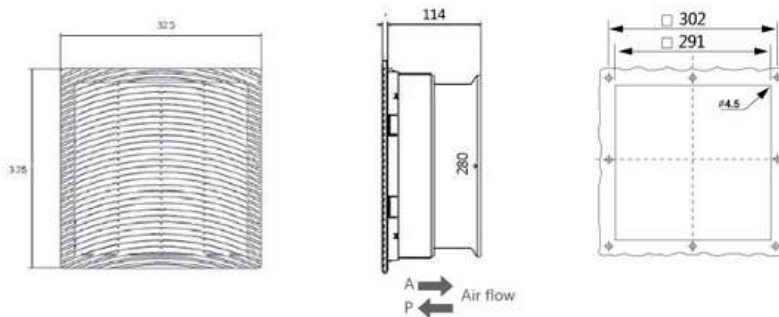
 Installing section  
FK 5528...

CODE		Exit filter	Fan and filter	Fan and filter
TYPE	M.U	FK5528.300	FK5528.230	FK5528.115
Voltage/Phase/Frequency	V-ph-Hz		230-1-50/1/60	115/1/50-60
Height/Width/Depth	mm	325×325×25	325×325×114	325×325×114
Power/Current	W/A		63/0.29	61/0.61
Temperature limits	°C		-30/+70	-30/+70
Protection degree	IP	54	54	54
Noise level	dB(A)		59	59
Air flow	m³/h		1150/1350	1150/1350
Air flow (+FK5526.300)	m³/h		360/490	360/490
Air flow direction			A	A

# FK5529 series filter

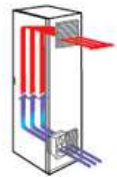

Cabinet Ventilation

Fan and filter	Fan and filter	Exit filter	Installing section
FK 5529...	FK 5529.230	FK 5529.300	FK 5529...

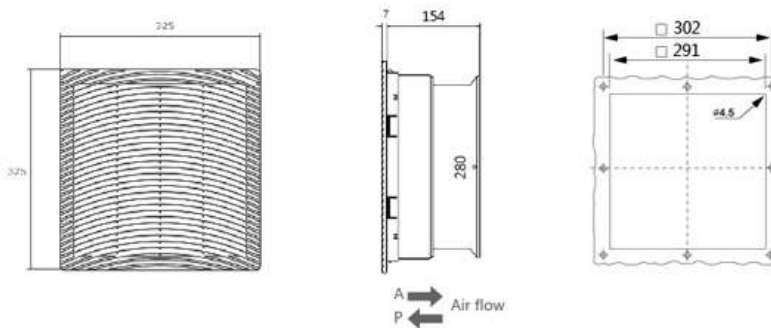

CODE		Exit filter	Fan and filter	Fan and filter
TYPE	M.U	FK5529.300	FK5529.230	FK5529.115
Voltage/Phase/Frequency	V-ph-Hz		230-1-50/1/60	115/1/50-60
Height/Width/Depth	mm	325×325×25	325×325×154	325×325×154
Power/Current	W/A		140.0-105.0 /0.62-0.48	136.0-110.0/1.2-1.1
Temperature limits	°C		-30/+70	-30/+70
Protection degree	IP	54	54	54
Noise level	dB(A)		63/65	63/65
Air flow	m³/h		1150/1350	1150/1350
Air flow (+FK5527.300)	m³/h		500/600	500/600
Air flow direction			A	A

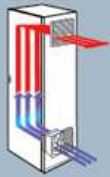

## Sketch Map

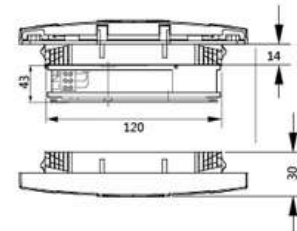
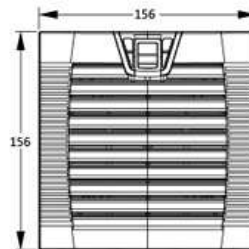
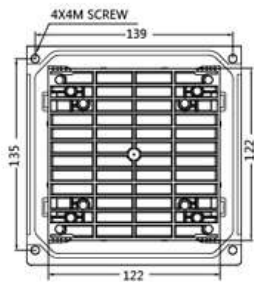

Model No. fan-and-filter unit LK	LK156.230	LK156.115	LK156.024
Rated operating voltage V, Hz	230, 50/60	115, 50/60	24 (DC)
Air throughput, unimpeded air flow	65/85 m <sup>3</sup> /h		85 m <sup>3</sup> /h
Air throughput with outlet filter including standard filter mat	1 x LK 156.300: 55/70 m <sup>3</sup> /h		
Axial fan	Self-starting shaded pole motor		DC motor
Rated current max.	0.12/0.10 A	0.24/0.20 A	0.35 A
Power	19.0/14.0 W		7.7 W
Noise level	36/40 dB(A)		40 dB(A)
Temperature range	-10 to +70°C		
Colour	RAL 7035		
Protection category to EN 60 529/09.2000	IP 54 standard IP 56 when using a hose-proof hood		
Model No. outlet filter LK	156.300		

# LK205 series filter



Cabinet Ventilation

## Sketch Map

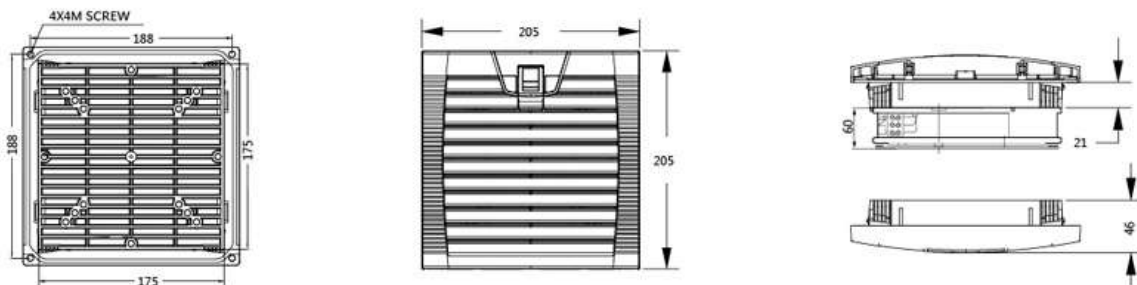

Model No. fan-and-filter unit LK	LK205.230	LK205.115	LK205.024
Rated operating voltage V, Hz	230, 50/60	115, 50/60	24 (DC)
Air throughput, unimpeded air flow	240/220 m <sup>3</sup> /h		220 m <sup>3</sup> /h
Air throughput with outlet filter including standard filter mat	1 x LK 205.300: 145/110 m <sup>3</sup> /h 2 x LK 205.300: 185/155 m <sup>3</sup> /h		1 x LK 205.300: 185/155 m <sup>3</sup> /h
Axial fan	Self-starting shaded pole motor		DC motor
Rated current max.	0.48/0.46 A	0.26/0.24 A	0.58 A
Power	41.0/38.0 W		14 W
Noise level	48/50 dB(A)		50 dB(A)
Temperature range	-30 to +70°C		
Colour	RAL 7035		
Protection category to EN 60 529/09.2000	IP 54 standard IP 55 when using an additional fine filter mat IP 56 when using an additional fine filter mat and hose-proof hood		
Model No. outlet filter LK	205.300		



Sketch Map

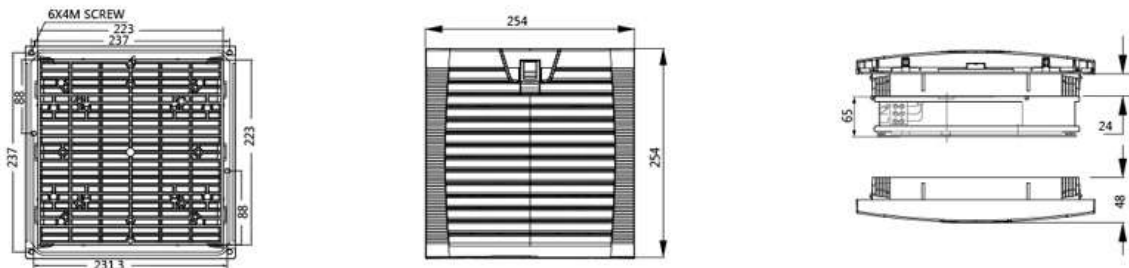

Model No. fan-and-filter unit LK	LK254.230	LK254.115
Rated operating voltage V, Hz	230, 50/60	115, 50/60
Air throughput, unimpeded air flow	550/600 m <sup>3</sup> /h	
Air throughput with outlet filter including standard filter mat	1 x LK 254.300: 500/600 m <sup>3</sup> /h 2 x LK 254.300: 650/800 m <sup>3</sup> /h	
Axial fan	Capacitor motor	
Rated current max.	0.48/0.46 A	0.24/0.26 A
Power	50 W	
Noise level	59 dB(A)	
Temperature range	-30 to +70°C	
Colour	RAL 7035	
Protection category to EN 60 529/09.2000	IP 54 standard IP 55 when using an additional fine filter mat IP 56 when using an additional fine filter mat and hose-proof hood	
Model No. outlet filter LK	254.300	

# LK321 series filter

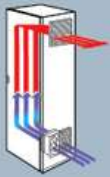

Cabinet Ventilation

## Sketch Map

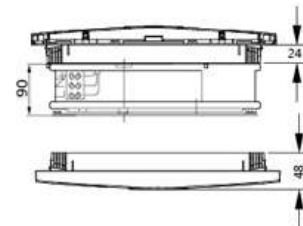
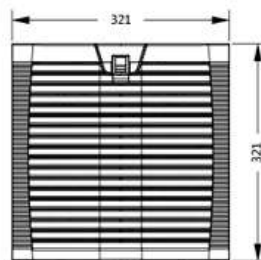
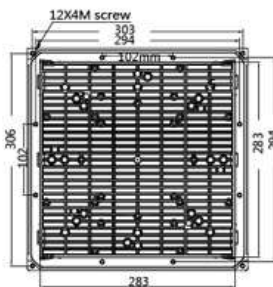

Model No. fan-and-filter unit LK	LK321.230	LK321.115
Rated operating voltage V, Hz	230, 50/60	115, 50/60
Air throughput, unimpeded air flow	580/700 m <sup>3</sup> /h	
Air throughput with outlet filter including standard filter mat	1 x LK 321.300: 380/410 m <sup>3</sup> /h 2 x LK 321.300: 460/515 m <sup>3</sup> /h	
Axial fan	Capacitor motor	
Rated current max.	0.34/0.30 A	0.64/0.60 A
Power	75.0/65.0 W	
Noise level	55/57 dB(A)	
Temperature range	-30 to +70°C	
Colour	RAL 7035	
Protection category to EN 60 529/09.2000	IP 54 standard IP 55 when using an additional fine filter mat IP 56 when using an additional fine filter mat and hose-proof hood	
Model No. outlet filter LK	321.300	

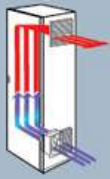

## Sketch Map

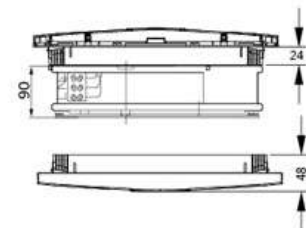
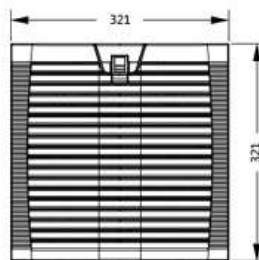
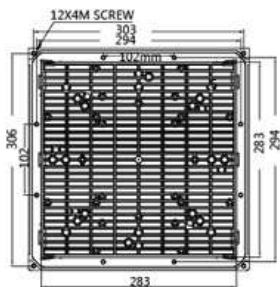

Model No. fan-and-filter unit LK	LK321.230-D	LK321.115-D
Rated operating voltage V, Hz	230, 50/60	115, 50/60
Air throughput, unimpeded air flow	1150/1350 m <sup>3</sup> /h	
Air throughput with outlet filter including standard filter mat	1 x LK 321.300: 750/950 m <sup>3</sup> /h	
Axial fan	Capacitor motor	
Rated current max.	0.62/0.48 A	1.2/1.1 A
Power	140.0/105.0 W	136.0/110.0 W
Noise level	63/65 dB(A)	
Temperature range	-30 to +70°C	
Colour	RAL 7035	
Protection category to EN 60 529/09.2000	IP 54 standard IP 55 when using an additional fine filter mat IP 56 when using an additional fine filter mat and hose-proof hood	
Model No. outlet filter LK	321.300	

# REF600 Cabinet top ventilator

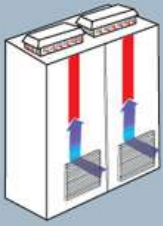

Adopting innovative mounting clamp, easily snap-in

## Features:

- Easy and fast snap in mounting that does not require screw
- Adjustable mounting clamps fit for different cabinet thickness range from 1.5 to 3.5mm
- IP54 protection, G3 standard filter pad
- Tool-less and quick replacement of the filter pad, just turn the button on the top
- RAL7035, other colors as per request
- AC voltages as standard type, DC voltages could be offered

## Dimensions

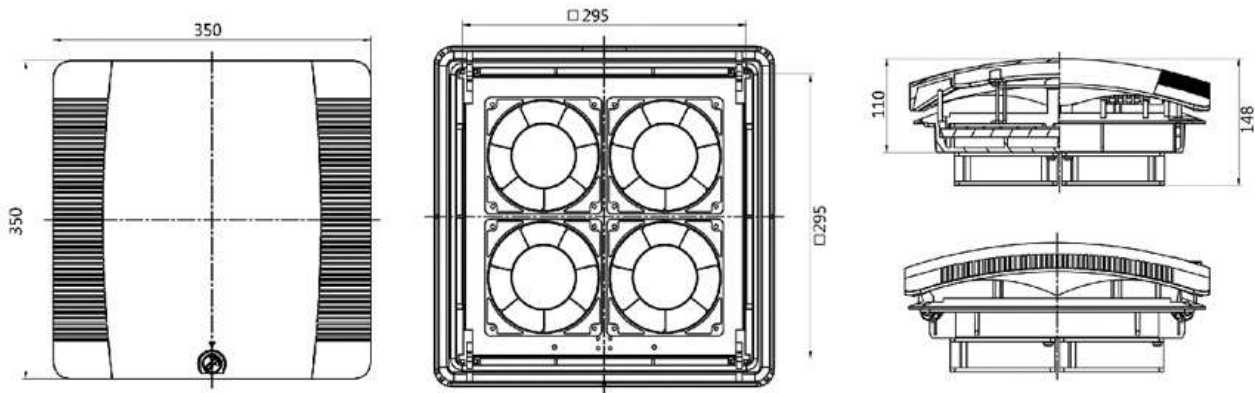

## Specifications

Model No.	REF600.230	REF600.115	REF600.024
Voltage frequency(Hz)	230V, 50/60	115V, 50/60	24V (DC)
Air flow(m <sup>3</sup> /h)	415 / 500	415 / 500	430 / 500
Rated current (A)	0.14 / 0.1	0.24 / 0.18	0.28 / 0.35
Power(W)	19/14	19 / 14	7.7
Noise level(dBA)	46 / 48	46 / 48	47 / 49
Temperature range	-30°C...+70°C	-30°C...+70°C	-30°C...+70°C
Dimensions(mm)	350x350x148	350x350x148	350x350x148
Fans dimensions(mm)	120x120x38*4	120x120x38*4	120x120x38*4
Mounting section size(mm)	295x295	295x295	295x295

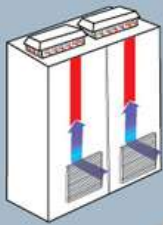

Adopting innovative mounting clamp, easily snap-in

**Features:**

- Easy and fast snap in mounting that does not require screw
- Adjustable mounting clamps fit for different cabinet thickness range from 1.5 to 3.5mm
- IP54 protection, G3 standard filter pad
- Tool-less and quick replacement of the filter pad, just turn the button on the top
- RAL7035, other colors as per request
- AC voltages as standard type

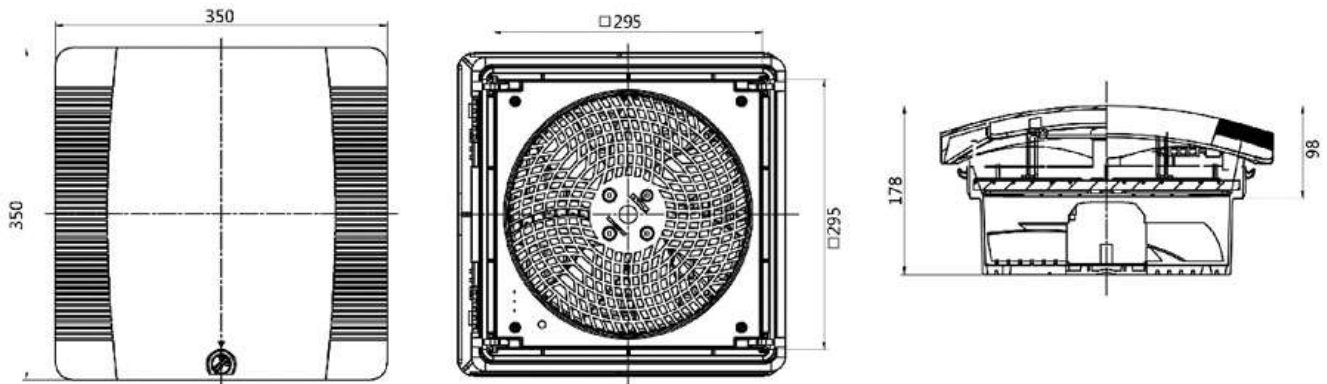
**Dimensions**

**Specifications**

Model No.	REF700.230	REF700.115	REF1400.230	REF1400.115
Voltage frequency(Hz)	230V, 50/60	115V, 50/60	230V, 50/60	115V, 50/60
Air flow(m <sup>3</sup> /h)	580 / 700	580 / 700	1150 / 1400	1150 / 1400
Rated current (A)	0.35 / 0.28	0.65 / 0.58	0.60 / 0.46	0.95 / 1.20
Fan starting	Capacitor-operated	Capacitor-operated	Capacitor-operated	Capacitor-operated
Power(W)	63 / 79	61 / 71	140 / 100	140 / 100
Noise level(dBA)	55 / 57	55 / 57	63 / 65	63 / 65
Temperature range	-30°C...+70°C	-30°C...+70°C	-30°C...+70°C	-30°C...+70°C
Dimensions(mm)	350x350x178	350x350x178	350x350x178	350x350x178
Fans dimensions(mm)	Φ 200	Φ 200	Φ 250	Φ 250
Mounting section size(mm)	295x295	295x295	295x295	295x295

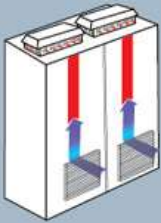
# KTF Cabinet top ventilator



Adopting innovative mounting clamp, easily snap-in

## Features:

### Easy to fit and maintain

- Innovative mounting clamps enables flexible snap-in the filter fan either from inside or outside of the enclosure
- Easily connecting with power supply via a plug
- Easy maintain, safe and quick replacement of filter pad

### Large air throughput range and high efficiency

- Air throughput range: 500-1000m<sup>3</sup>/h

### High protection level

- An exquisite labyrinth construction and super quality polyurethane foam seal ensures the ingress protection rate up to IP55
- International certification and approval

color: RAL 7035

Protection class, conform to IEC60529 standard:

without filter mat

with filter mat

Note: Use of a temperature controller or temperature display device is suggested for optimal performance.

Supply lists :

A complete set of assemblies for installation directly on cabinet, including filter mat

Air throughput, free air flow : 500-942 m<sup>3</sup>/h

Model No.	KTF3139.100	KTF3139.110	KTF3140.100	KTF3140.110	KTF3140.140
Rated voltage (V,~,Hz)	230, 1~, 50/60	115, 1~, 50/60	230, 1~, 50/60	115, 1~, 50/60	400, 3~, 50/60 460, 3~, 60
Air throughput, free air flow(without filter mat)	500 / 525	500 / 525	873 / 965	873 / 965	863 / 942
Air throughput, free air flow(with filter mat)	417 / 446	417 / 446	725 / 759	725 / 759	700 / 749
Rated current (A)	0.27 / 0.22	0.55 / 0.43	0.56 / 0.43	1.17 / 0.88	0.19 / 0.11
Fuse current (A)	6	6	6	6	-
Motor short circuiter (A)	-	-	-	-	6.3...10
Power (W)	62 / 50	62 / 49	130 / 98	135 / 101	122 / 90
Width (mm)	400	400	400	400	400
Height (mm)	133	133	133	133	133
Depth (mm)	400	400	400	400	400
Max.mounting depth (mm)	34.6	34.6	34.6	34.6	34.6
Required mounting section size (mm)	258x258	258x258	258x258	258x258	258x258
Fan type	Centrifugal capacitor motor				
Operating temperature range	-30°C...+55°C				
Storage temperature range	-40°C...+70°C				

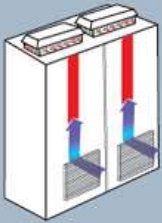

Temperature



Humidity

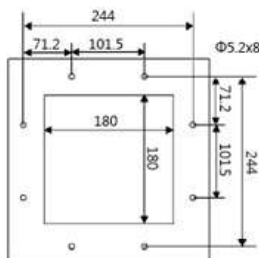
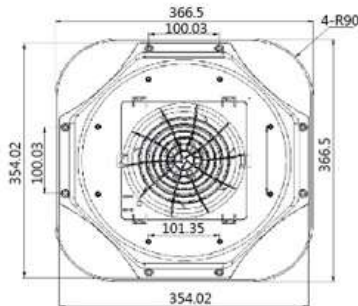
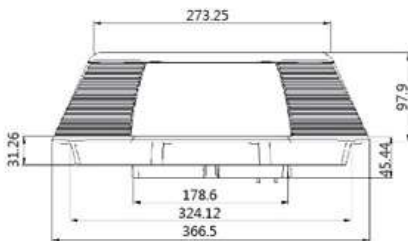

### Technical explanation:

The premise of using top-mounted fan:

Ambient temperature should be lower than the temperature that is required to be in the switchboard. Taking top-mounted fan into account when there isn't enough space for a side-mounted filter fan in the cabinet.

Top-mounted fan of the cabinet will bleed the air from the top of the cabinet and drive the heat out so as to protect the electric apparatus and keep them running at the temperature within controllable range. And the structure is more proper because it won't take up space in the cabinet.

EN 60529/10.91 reaches IP54. The retractable high-power centrifugal fan is able to prevent moisture as well as mechanical damage, with its labyrinth rain-proof structure, which with the help of the sealing frame, can reach an IP code up to IP54 as per EN 60529/10.91. The centrifugal fan is mainly useful for discharge of high-heat load at peak efficiency.

Adoption of the centrifugal fan will be able to reduce the noise resulting from air friction as well as avoiding the vortex discharged by normal shaded pole fan.

The quantity and dimensions of inlet filters could be determined according to the actual situation.

Please mark B behind corresponding model if a stainless shell required.

We can provide products with different voltage as required by clients.



Using LK33 or EF series Exit Filters at the side of the cabinet not only can prevent water and dust entering the cabinet, also make the air through the whole cabinet for cooling.

Exhauster on the top	Type	KRF-670	KRF-950	KRF-1410
Voltage Frequency			230V 50/60HZ	
Air flow/free discharge of air		620/670m <sup>3</sup> /h	910/950m <sup>3</sup> /h	1250/1410m <sup>3</sup> /h
Centrifugal fan			Capacitor start	
Rated current		0.31/0.24A	0.38/0.36A	0.62/0.58A
Power		72/56W	88/82W	190/130W
Noise level		55/56 dBA	60/62 dBA	65/70 dBA
Temperature range			-10°C~55°C	

The quantity and size of the air inlet filter meet the requirements of particular users

# F2E Cabinet top ventilator

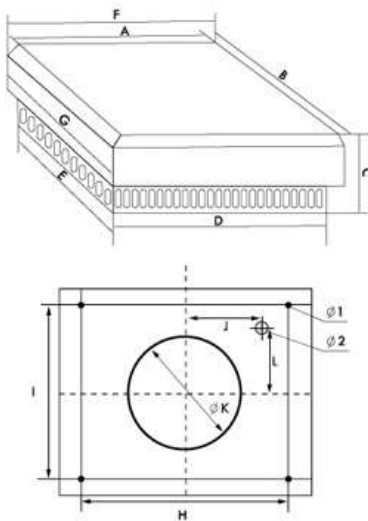
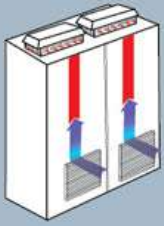

Power specific property curve

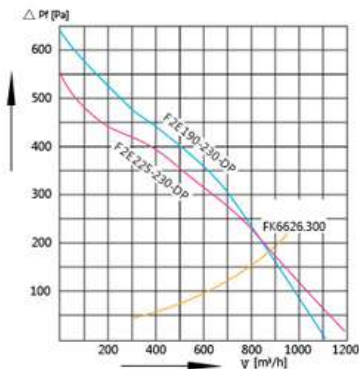

## Interior

The precondition to use the top fan is that the ambient temperature should be lower than the temperature required in the cabinet.

## Function

The high-power centrifugal top fan can vent the high heat load by the greatest degree. The centrifugal fan not only can avoid the vortex vented by the general shield magnetic fan, but also can reduce the noise caused by the friction of air. The FK series of Exit Filter can be used in the inlet in order to prevent from entering the humidity and dust.

## Design

The centrifugal top fan is larruping. It is handsome and it has the good function and reasonable structure. It also doesn't take up the interior space. It can well satisfy requirement of the present market with it's unique design.

Type	A/B	C	D/E	F/G	H/I	J	ΦK	Φ1	Φ2	L
F2E190-230-DP	270	130	267	310	226.8	98.4	195	7.8	15	97
F2E 220-230-DP	270	130	267	310	226.8	98.4	195	7.8	15	97
F2E 225-230-DP	270	130	267	310	226.8	98.4	195	7.8	15	97

Exhauster on the top	Type	F2E190-230-DP	F2E220-230-DP	F2E225-230-DP
Voltage Frequency		230V 50/60HZ	230V 50/60HZ	230V 50/60HZ
Air flow, Ventilation freely		570/620m³/h	860/900m³/h	1200/1340m³/h
Flux of air equip filter exported Include filtering pad of standard		1xFK6626.300	1xFK6626.300	1xFK6626.300
Axle flow blower		456/496m³/h	688/540m³/h	960/1072m³/h
Rated current		Capacitance electromotion	Capacitance electromotion	Capacitance electromotion
Power		0.34/0.26A	0.40/0.38A	0.88/0.60A
Noise level		75/58W	90/85W	200/135W
Temperature range		62/64 dBA	73/74 dBA	69/71 dBA
		-10°C~55°C	-10°C~55°C	-10°C~60°C

The quantity and size of the wind inlet filter can be decided according to the concrete requirement

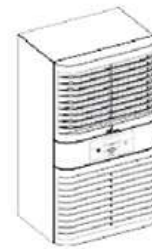

Side mounting



Installation opening size

### Features:

- Intelligent inverter control, without transient electric current, up to 40 % less energy- consumption.
- Complete isolation inside and outside,dust-proof, oil&mist proof,moisture-proof etc.
- Compact size , Compatible with main models in the industry.
- Flexible working temperature adjustment from 15 ℃ ~55 ℃.
- Chinese and English bilingual LCD display menu , easy access to parameter setting and alarm information checking.
- Providing MODBUS communication , with power on START-UP function.
- Dust-proof net plug,quick change conveniently.
- Condensate water treatment, efficient solution to the problem of condensate discharge.
- Nano coating, anti-corrosion ability.
- Selectable smoke, access control and flooding alarm.
- 7\*24\*365 uninterrupted operation for more than 10 years.

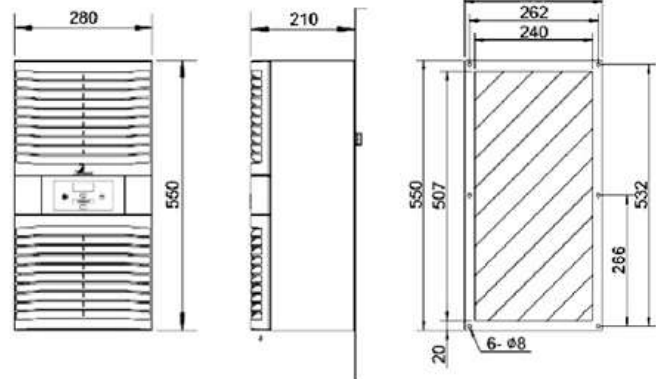

### Products Specification

Model	EIA05
External Dimension-Height(mm)	550
External Dimension-Width(mm)	280
Dimension-Depth(mm)	210
Quality-kg	<17
Installation Mode	outdoor (side mounting)
Working Temperature- °C	-15 ~ +55
Noise Level-dB(A)	65
IP protection class	IP54
Refrigerant	R134a
Refrigerating capacity@L35/L35-W	500/550
Input power@L35/L35-W	260/280
Input current @L35/L35-A	1.3/1.35
Rated Voltage-V,Hz	1~,220,50/60

# EIA Industrial Air-cooled Conditioner (1000-2000W)

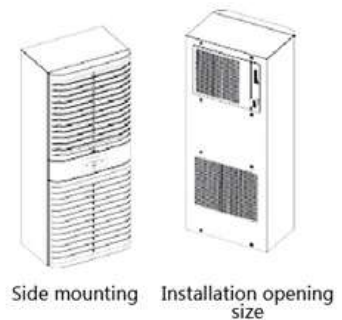

## Features:

- Intelligent inverter control, without transient electric current, up to 40 % less energy- consumption.
- Complete isolation inside and outside,dust-proof, oil&mist proof,moisture-proof etc.
- Compact size , Compatible with main models in the industry.
- Flexible working temperature adjustment from 15℃ ~55℃.
- Chinese and English bilingual LCD display menu , easy access to parameter setting and alarm information checking
- Providing MODBUS communication , with power on START-UP function.
- Dust-proof net plug,quick change conveniently.
- Condensate water treatment, efficient solution to the problem of condensate discharge.
- Nano coating, anti-corrosion ability.
- Selectable smoke, access control and flooding alarm.
- 7\*24\*365 uninterrupted operation for more than 10 years.

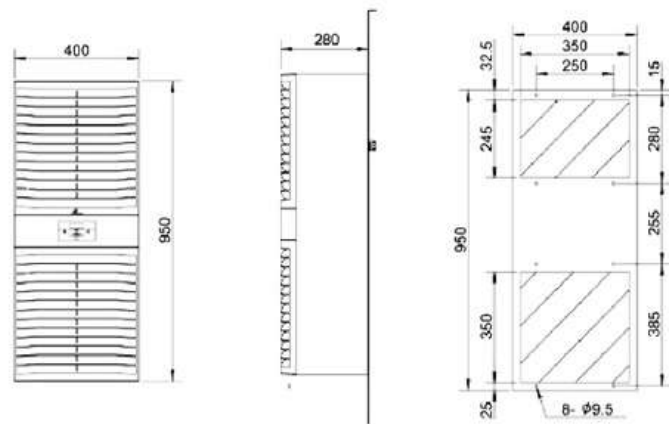

## Products Specification

Model	EIA10	EIA15	EIA20
External Dimension-Height(mm)	950	950	950
External Dimension-Width(mm)	400	400	400
Dimension-Depth(mm)	280	280	280
Quality-kg	<41	<41	<41
Installation Mode	outdoor (side mounting)	outdoor (side mounting)	outdoor (side mounting)
Working Temperature- °C	-15~ +55	-15 ~ +55	-15~ +55
Noise Level-dB(A)	65	65	65
IP protection class	IP 54	IP 54	IP 54
Refrigerant	R134a	R134a	R134a
Refrigerating capacity@L35/L35-W	1100/1300	1500/1700	2000/2100
Input power@L35/L35-W	540/680	750/900	1000/1200
Input current @L35/L35-A	2.5/3.2	3.5/4.2	4.6/5.7
Rated Voltage-V,Hz	1~,220,50/60	1~,220,50/60	1~,220,50/60



### Features:

- Intelligent inverter control, without transient electric current, up to 40 % less energy- consumption.
- Complete isolation inside and outside,dust-proof, oil&mist proof,moisture-proof etc.
- Compact size , Compatible with main models in the industry.
- Flexible working temperature adjustment from 15°C ~55°C.
- Chinese and English bilingual LCD display menu , easy access to parameter setting and alarm information checking.
- Providing MODBUS communication , with power on START-UP function.
- Dust-proof net plug,quick change conveniently.
- Condensate water treatment, efficient solution to the problem of condensate discharge.
- Nano coating, anti-corrosion ability.
- Selectable smoke, access control and flooding alarm.
- 7\*24\*365 uninterrupted operation for more than 10 years.

### Products Specification

Model	EIA40
External Dimension-Height(mm)	1580
External Dimension-Width(mm)	500
Dimension-Depth(mm)	340
Quality-kg	89
Installation Mode	Side mounting / door mounting
Working Temperature- °C	-15 ~ +55
Noise Level-dB(A)	65
IP protection class	IP54
Refrigerant	R134a
Refrigerating capacity@L35/L35-W	4000/4500
Input power@L35/L35-W	1900/2600
Input current @L35/L35-A	3.1/4.2
Rated Voltage-V,Hz	3~,380,50/60
Air switch-P,A	3,10

# EIA Industrial Air-cooled Conditioner (4000W)

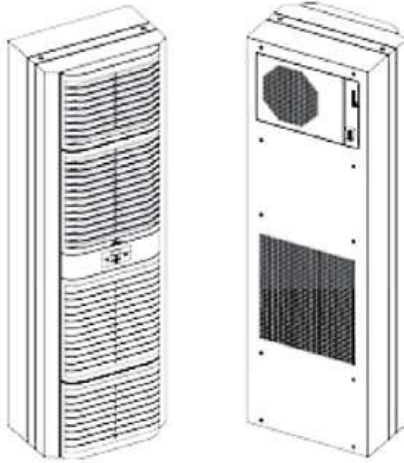

Side mounting

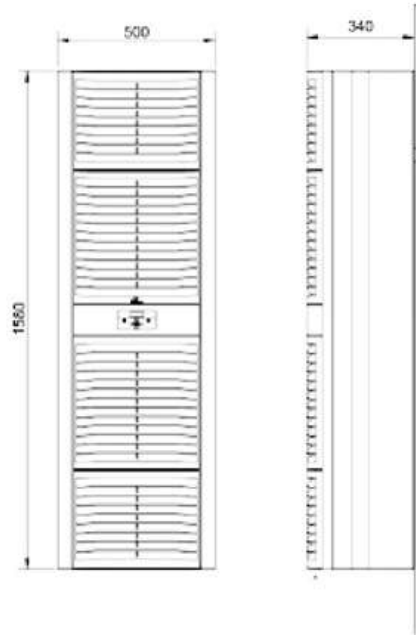

Installation opening size

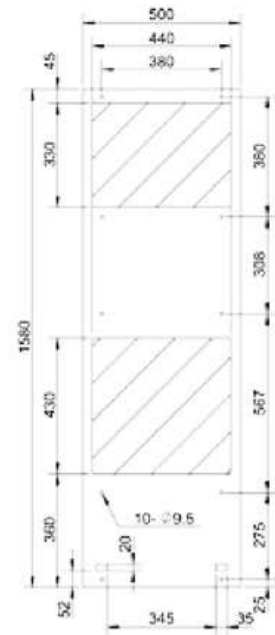

door mounting

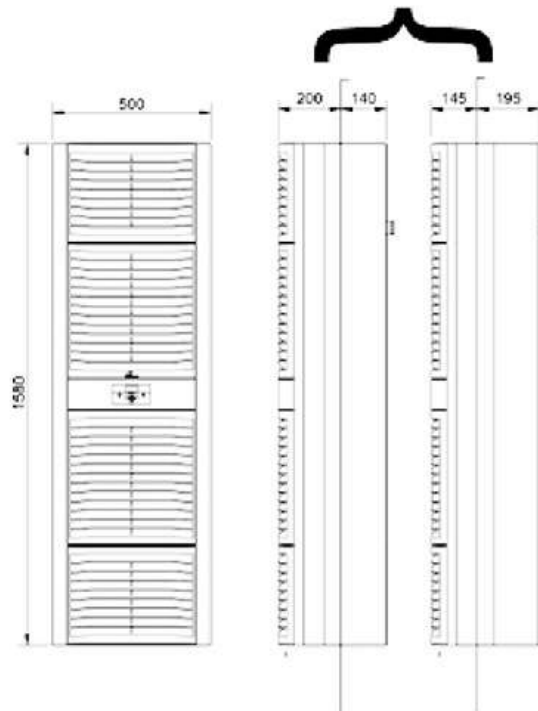

Installation opening size

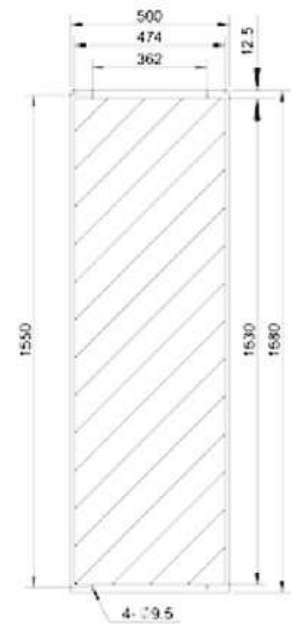



# Heater/Thermostat /Hygromstat

# KTH-082 Temperature&Humidity Remote Controller



## Overview

Adopting the MCU control system, the product provide a real time monitoring and controlling over temperature and humidity, which assures an appropriate ambient temperature and humidity through intelligent climate control.

## Specifications

Input voltage	AC220V±10%, Other voltages can be customized
Humidity range	20-90%RH ( no condensation )
Humidity accuracy	±5%RH ( at 25°C )
Temperature range	-20-80°C
Temperature Accuracy	±1°C ( at 25°C )
Humidity set range	20-80%RH
Operating temperature/humidity	temperature -20°C--60°C, humidity 10--95 %RH ( no condensation )
Storage temperature/humidity	temperature -10°C ~ 40°C, humidity10- 90%RH ( no condensation )
Switching capacity	pure resistance load AC250V/10A, DC30V/5A
Power down memory	Intelligent memory for its preset parameter in case of power failure

## 1.Functions

1.1The temperature and humidity values are displayed on a high definition LCD screen.Displaying diagram as below:

- ◆ Displaying humidity measurement by 2 digits, i.e: 60%RH
- ◆ Displaying humidity set value : In the set state, 500ms/time , humidity set value is blinking ,i.e: 40%RH.
- ◆ Displaying temperature measurement value by 2 digits, i.e: 25°C
- ◆ Displaying temperature set value : In set state, 500ms/ time. temperature set value is blinking: i.e.: 25°C.
- ◆ Dehumidifying mode indication:  
When the equipment is in dehumidifying mode, it display the status by the dynamic fan.
- ◆ Heating mode indication:  
when the equipment is in heating mode, it display the status by heating signal.



## 1.2Button

- ◆ "POWER": Press this button to switch on or off.
- ◆ "SET": In the boot state, press this button, the product is in setting mode for temperature of humidity. Meanwhile, the digital display of humidity or temperature blinking.If no button press within 10 seconds, it automatically exit the setting status .
- ◆ "PLUS":In the set state, press this button, the set values increase one as per each single press. The max. Humidity set value is 80%RH,and the max. temperature set value is 60°C.Exiting setup automatically, if no button press in 10 seconds
- ◆ "MINUS":In the set state, press this button, the set values decrease one as per each single press. The min. Humidity set value is 10%RH,and the min. temperature set value is 5°C.Exiting setup automatically, if no button press in 10 seconds



## 2. Output Control

### 2.1 Humidity Output Control

If the measured humidity exceeds the set value, output relay closed for dehumidifying. And the dynamic fan displays the operation status. If the measured humidity are 5% RH less than the set value, dehumidifying stopped, the dynamic fan indicator off. The humidity difference are 5%RH so as to avoid the frequent switch over the critical point which shorten service time.

With initial power on, there are 3 seconds' time-delay from output control, i.e. The dehumidifying controller starts action in 3 seconds under the right humidity, indicator display the running mode.

### 2.2 Temperature Control Output

If the measured temperature exceeds the set value, the output relay closed for heating. Thus the heating signal display the operation status. If the measured temperature are 2 °C less than the set value, heating stopped, the heating signal off. The heating difference are 2 °C so as to avoid the frequent switch over the critical point which shorten the service time.

With initial power on, there are 3 seconds' time-delay from output control, i.e. The heating relay controller starts action in 3 seconds under the right humidity, indicator displays the running mode.

### Power down memory protection

With power down memory protection, it could save user' s setting parameter on equipment in case of sudden power off.

### Communication

This product adopts 485 communication mode, which allow the temperature, humidity parameter and running status to be uploaded to the remote computers. The display mode as below:

### Temperature&Humidity Remote Control Display System

Enclosure No.	Measured Temperature	Measured Humidity	Running State
1#	25°C	60%RH	Running
2#	25°C	60%RH	Stop
3#	25°C	60%RH	Running
4#	25°C	60%RH	Stop
5#	25°C	60%RH	Stop

It can display the temperature, humidity parameter and running status of 5 cabinet enclosures at same time.

## 3. Dimensions and connection diagram

### 3.1 Flush mounted controller, opening size 82.5\*82.5mm

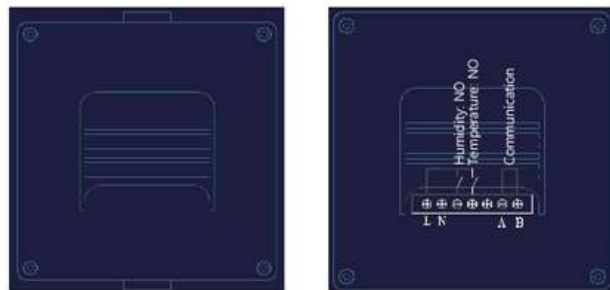

### 3.2 Terminal block diagram at backside of controller

- ( 1 ) Power: AC220V/50HZ: Connect power supply with terminal L and N
- ( 2 ) Load Terminal: Connect the heater with NO contact ; Connect the fan with NC contact .
- ( 3 ) 485communication terminals; connect A and B

## 4. USB Converter Connector

### 4.1 USB terminal on the left side :

Connect with the USB port on the computer, installation requires a USB drive (see details on 485USB drive);

### 4.2 RS485 on the right side: connect controller with terminal A and B.



# KTOMF 012/KTSMF 012 Thermostat



## Benefits:

- Integrated integration: AC input, AC output, offering convenience in use.
- With LED indicator, easier to recognize working state.
- Small size for a variety of applications.
- Stable long - time operating.
- ROHS compliant.

## Features:

- Humidity control: If the relative humidity exceeds the value set on the humidity dial, the electric circuit is cut off. Return difference is 5 - 10% RH.
- Temperature control: If the ambient temperature rises above the value set on the temperature dial, the electric circuit is cut off. A tolerance of 1 - 3°C is allowed.
- Power: AC220V. Other voltage is alternative.
- Current: Max 46mA.
- Operating conditions: Temperature: - 10 to 50°C; Humidity: 40 - 90%RH.
- Storage conditions: Temperature: - 20 to 60°C; Humidity: 20 - 95%RH.
- Humidity sensor: Polymer humidity resistance.
- Temperature sensor: Bimetal sensor.

## Elements:

- Set up the operation range by adjusting the knob. When the relative humidity drops below the value pre - set, the electric circuit is closed via terminal LED illuminates. When the relative humidity rises above the value pre - set, the electric circuit is cut off via terminal LED blacks out. In order to protect the loads not to work too frequently, the return difference is 5 - 10%RH, means the electric circuit is closed when the humidity drops 5 - 10% below more than the value pre - set.
- Set up the operation range by adjusting the knob. When the ambient temperature drops below the value pre - set, the electric circuit is closed via terminal LED illuminates. When the ambient temperature rises above the value pre - set, the electric circuit is opened via terminal LED blacks out.

Humidity switching difference	4%RH(±3% tolerance)
Temperature switching difference	7k(±4k tolerance)
Temperature sensor element	Bimetal sensor
Relative humidity range	35% - 95%RH
Temperature control contact mode	Step type contact point
Humidity control contact mode	Chang - over switch
Mean life	750,000 cycles
Min Switching capacity	20VAC/DC 100m A
Max Switching capacity	250VAC/DC 5(1)A DC30W
Connection	5 - pole terminal, clamping torque 0.5Nm Max for solid wire 2.5mm <sup>2</sup> and stranded wire(with wire and ferrule) 1.5mm <sup>2</sup>
Installation	35mm Din rail
Casing	UL94V - 0, light grey
Dimension	70x63x40mm
Weight	90g
Fitting position	Cabinet top
Operating temperature	0 - +60°C(+32 - +140°F)
Storage temperature	- 20 - +80°C(- 4 - +176°F)
Protection level	IP20



- Large setting range
- Small size
- Simple to mount
- High switching performance

**KTO 011:** Thermostat (normally closed); contact breaker for regulating heaters.

**KTS 011:** Thermostat (normally open); contact maker for regulating filter fans and heat exchangers or for switching signal device when temperature limit has been exceeded.

**Installing method**

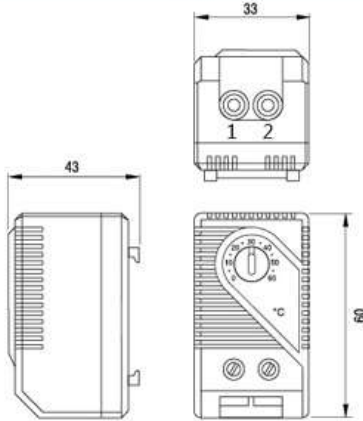

Temperature range	0-60°C
KTO 011 NC (Normally closed)	When the temperature reaches the set value, open circuit
KTS 011 NO (Normally open)	When the temperature exceeds the set value action, closed circuit
Switch temperature difference	7K(±4K tolerance)
Sensor element	thermostatic bimetal
Contact type	Snap-action
Contact resistance	< 10m ohm (Incidental connection line)
Service life	> 100,000 cycles
Max. Switching capacity	250VAC, 10(2)A
	120VAC, 15(2)A
	30WDC at 24VDC to 72VDC
Connection	2-pole terminal, clamping torque 0.5Nm max.: rigid wire 2.5mm <sup>2</sup> , stranded wire (with wire end ferrule) 1.5mm <sup>2</sup>
Casing	plastic according to UL94 V-0, light grey
Installation	35mm DIN Installation guide
Dimensions	60×33×43mm
Weight	40g
fitting position	variable
Operating/Storage temperature	-20°C to +80°C
Protection type	IP20

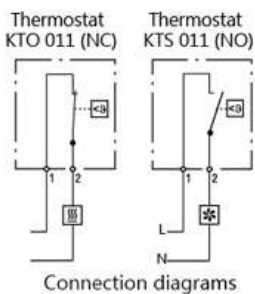

Heater  
Filter fan, Cooling equipment, Signal device

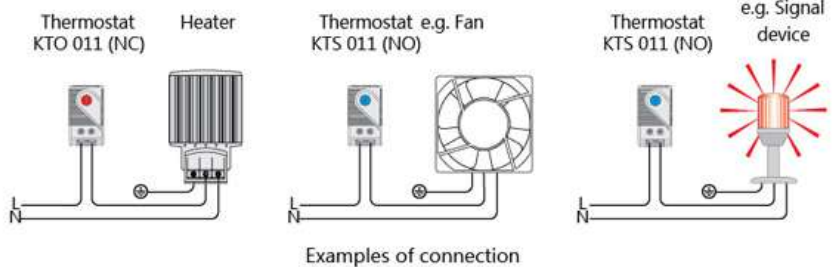

Setting range 0 to +60°C	Art. No. Contact Breaker (NC) <b>KTO 011</b>	Art. No. Contact Maker (NO) <b>KTS 011</b>	Approvals CE
-----------------------------	---	---	-----------------

# KNO 011/KNC 011 New Panel Thermostat



## Panel thermostat

- Small, compact size (17.5mm wide)
- Long electrical life
- Snap action thermostatic Bimetal sensor
- 35mm rail (EN 60715) mount
- Wide temperature setting range

**Heating control** - Should the panel temperature fall below the (minimum) set temperature the contact will close to call for heat. The contact will open when this set temperature is exceeded.

**Ventilation control** - Should the panel temperature exceed the (maximum) set temperature then the contact will close to call for cooling. The contact will open when the temperature falls below this set temperature.

## • Heating control

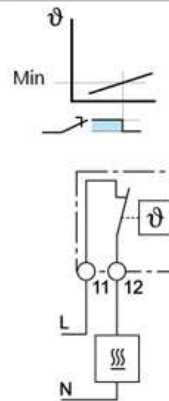

## • Ventilation control

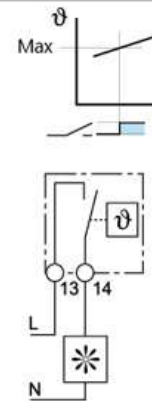

Contact specification			
Contact configuration		1 NC	1 NO
Rated current/Maximum peak current	A	10/20	10/20
Rated voltage/ Maximum switching voltage	V AC	250/250	250/250
Rated load AC1	VA	2500	2500
Rated load AC 15 (230V AC)	VA	250	250
Single phase motor rating AC 3 (230V AC)	kW	0.125	0.125
Breaking capacity DC 1:30/110/220 V	A	1/0.3/0.15	1/0.3/0.15
Minimum switching load	mW (V/mA)	500 (12/10)	500 (12/10)
Standard contact material		AgNi	AgNi
Temperature setting range			
Setting range (ventilation)	°C	—	-20...+40   +0...+60
Switch temperature differential	K	—	7±4
Setting range (heating)	°C	-20...+40   +0...+60	—
Switch temperature differential	K	7±4	—
Technical data			
Electrical life at rated load AC1	cycles	100 · 10 <sup>3</sup>	100 · 10 <sup>3</sup>
Ambient temperature range	°C	-45...+80	-45...+80
Protection category		IP 20	IP 20

**Ordering information**

Example: KNC/KNO Series, thermostat for ventilation control, contact activates ventilation should the panel temperature exceed the set value (max+60°C),35mm rail (EN 60715) mount.

**Technical data**

Insulation			
Dielectric strength between open contacts	V AC	500	
Other data			
Screw torque	Nm	0.5	0.5
Max. wire size		solid cable	stranded cable
	mm <sup>2</sup>	1×2.5	1×1.5
	AWG	1×12	1×16
Model No.		KNO 011	NO Type for heating
		KNC 011	NC Type for cooling

**Outline drawings**
**Screw terminal**

Alarm output contact, Passive contact, AC250V 5A.

NO, close while function of dehumidifier is out of order.

Function out of order defined: Temperature sensor or humidity sensor fault; Duration of Dehumidifier work is over 24 hours, RH≥80%RH.

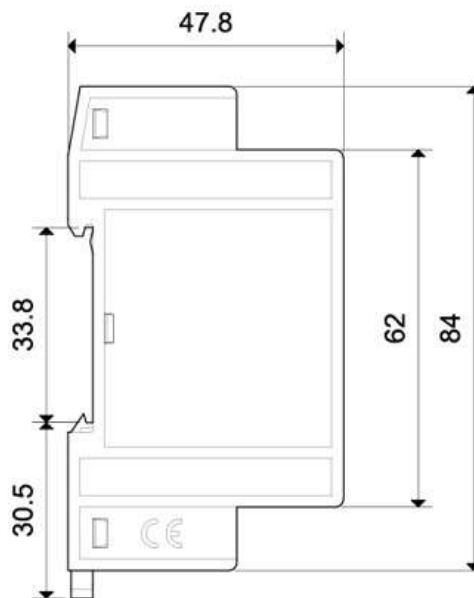
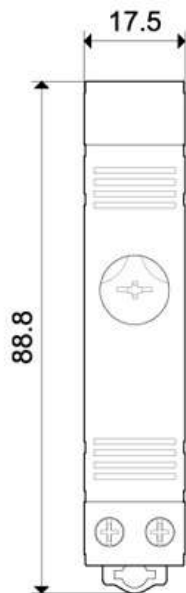

# ZR 011 Dual Thermostat



- NO and NC in one casing
- Separate adjustable temperatures
- High switching capacity
- Terminals easily accessible
- Clip Fixing

Two thermostats in one casing:

Thermostat(contact breaker, normally closed)for regulating heaters  
Thermostat(contact make, normally open) for regulating filter fans and heat exchangers or switching signal devices when temperature limit has been exceeded.

Heaters and cooling equipment can be switched independently from each other with a temperature offset a he usual change-over contacts.

Size chart

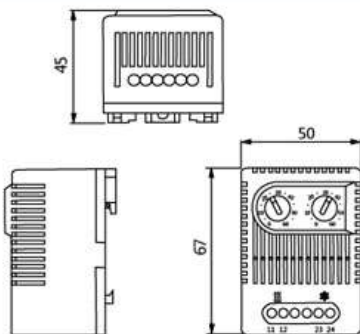

Temperature range	NO/NC:0-60°C
Switch temperature difference	7K(+4K tolerance)
Sensor element	thermostatic bimetal
Contact type	Snap-action
Contact resistance	<10m ohm
Service life	>100,000 cycles
Max. Switching capacity	250VAC,10(2)A
	120VAC,15(2)A DC 30W
Connection	4-pole terminal, clamping torque 0.5Nm max.: rigid wire 2.5mm <sup>2</sup> , stranded wire (with wire end ferrule) 1.5mm <sup>2</sup>
Installation	35mm DIN Installation guide
Casing	UL94 V-0 Plastic, light gray
Dimensions	67×50×46mm
Weight	90g
fitting position	variable
Operating/Storage temperature	-20°C to +80°C
Protection type	IP20

Thermostat  
ZR 011(NC/NO)

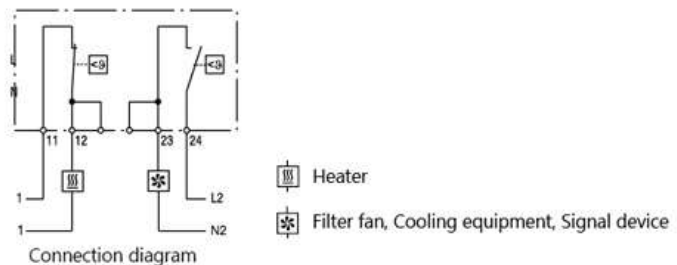

Art. No.	Setting Range		Setting Range	
	ZR 011	Contact breaker (NC)	0 to +60°C	Contact maker (NO)

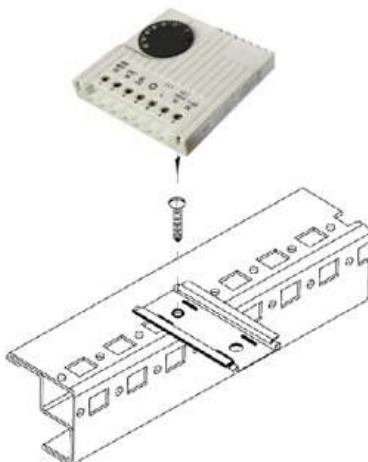
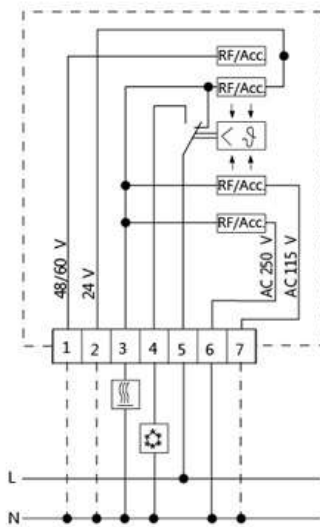



- Bi-metal controller as a temperature sensitive element with thermal feedback.
- Contact population: Single-pole change-over contact as a quick-break contact.
- Permissible contact load:  
Cat. 5 - 3 (heating) AC 10 (4\*) A, DC = 30 W Cat. 5 - 4 (cooling) AC 5 (4\*) A, DC = 30 W \* ( ) = inductive load at  $\cos \phi = 0.6$   
Setting range: 0 °C to + 60 °C
- Weight: 105g appr Size: 71x71x33.5mm Switch discrepancy: 1K ± 0.8K
- Voltage scope is wide, any type could be used from 24V to 230 V
- Time-saving connection, terminal block could be installed screw from outside
- Easy installation, could be installed to 35mm din rail vertically or horizontally, according to EN50 022, it could be clipped to TS/35 cabinet profile with its accessory adapter.

Application Especially suitable for controlling fan-and-filter units, heaters and heat exchangers, this thermostat can also be used as a signal generator for monitoring the enclosure internal temperature.

Sensing element	Bimetallic
Shock configuration	Conversion of electric shock as a transient unipolar switching elements
Permissible contact load	Cat. 5 - 3 (heating) AC 10 (4*) A, DC = 30 W Cat. 5 - 4 (cooling) AC 5 (4*) A, DC = 30 W * ( ) = inductive load at $\cos \phi = 0.6$
Temperature adjustment range	0°C to +60°C
Rated voltage	230/115/60/48/24V (AC) 60/48/24V (DC)
Weight	105g
Size	71X71X33.5mm
Switching difference	1K ± 0.8K

**Rated voltage**  
230/115/60/48/24V(AC)  
60/48/24V (DC)

48V 60V N	24V N			(L1*) L	(L2*) 250V N	115V N
1	2	3	4	5	6	7

# MFR 012 Electromechanical Hygrostat



- Adjustable relative humidity
- Easily accessible terminals
- Change-over contact
- Clip fixing
- High switching capacity

The electromechanical hygrostat is designed to control enclosure heaters so that the dew point is raised when a critical relative humidity of 65% is exceeded. In this way condensation and corrosion in enclosures with electric/electronic components is effectively prevented.

## Connection

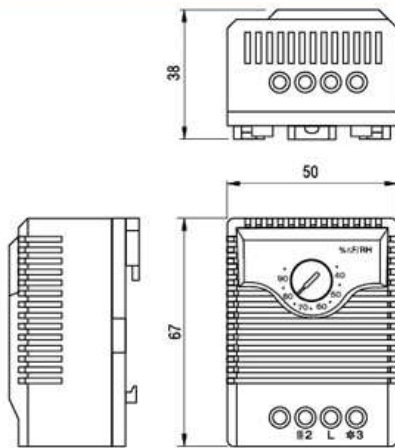

Switching error	4% RH ( $\pm 3\%$ tolerance)
Relative humidity range	35%-95%
Allow wind speed	15m/sec
Contact type	Changeover contact
Contact resistance	<10m ohm
Service life	>50,000 cycles
Mix. Switching capacity	20V AC/DC 100 mA
Max. Switching capacity	25 VAC, 5 A
Connection	3-pole terminal for 2.5mm <sup>2</sup> , clamping torque 0.5Nm max.: rigid wire 2.5mm <sup>2</sup> , stranded wire (with wire end ferrule) 1.5mm <sup>2</sup>
Installation	35mm DIN Installation guide
Casing	UL94 V-0 Plastic, light gray
Dimensions	67x50x38mm
Weight	about 60g
Fitting position	variable
Operating/Storage temperature	0 ~ +60°C (+32 ~ +140°F) / -20 ~ +80°C (-4 ~ +176°F)
Protection type	IP20

Heater/Thermostat/Hygrostat

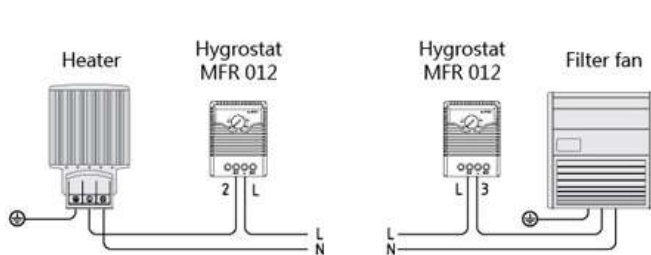

Examples of connection

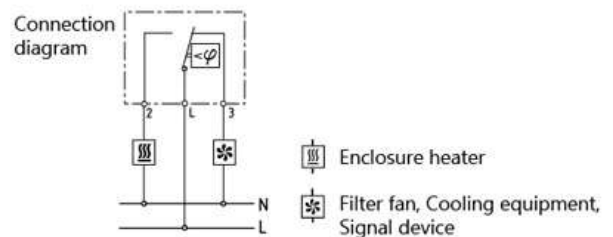

Art. No. <b>MFR 012</b>	Setting range 35 to 95% RH
----------------------------	-------------------------------



- Adjustable relative humidity
- Change-over contact
- High switching capacity
- Easily accessible terminals
- Clip fixing

The electromechanical hygrostat is designed to control enclosure heaters so that the dew point is raised when a critical relative humidity of 65% is exceeded. In this way condensation and corrosion in enclosures with electric/electronic components is effectively prevented.

Switch difference*	4% RH (± 3% tolerance)
Permissible air velocity	15m/sec.
Contact type	change-over contact
Service life	>50,000 cycles
Mix. Switching capacity	250VAC, 5A 20WDC
Max. Switching capacity	5AAC
Connection	3-pole terminal for 2.5mm <sup>2</sup> , clamping torque 0.5Nm max.; rigid wire 2.5mm <sup>2</sup> stranded wire (with wire end ferrule) 1.5mm <sup>2</sup>
Mounting	clip for 35mm DIN rail, EN 60715
Casing	plastic according to UL94 V-0, light grey
Dimensions	67 x 50 x 38mm
Weight	approx. 60g
Fitting position	variable
Operating / Storage temperature	0 to +60°C (+32 to +140°F) / -40 to +60°C (-40 to +140°F)
Operating / Storage humidity	max. 90% RH (non-condensing)
Protection type	IP20
Approvals	UL File No. E164102

Connection

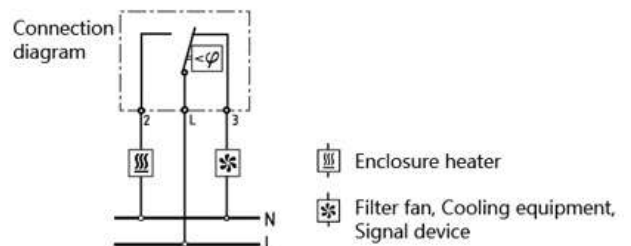
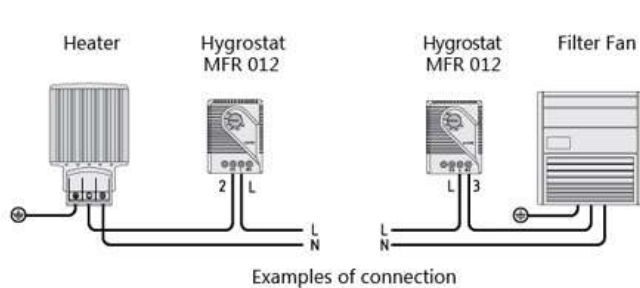
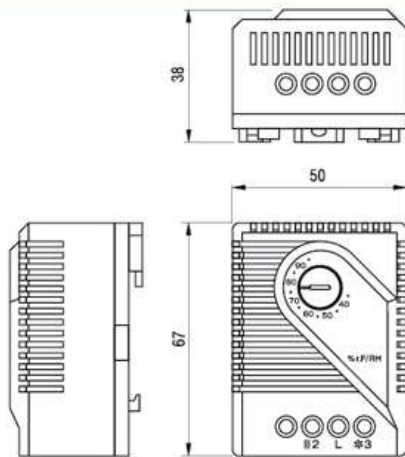

Art. No.	Setting range
MFR012-2	35 to 95% RH

# EFR012 Electronic Hygrostat



- Temperature and humidity adjustable
- Optical operating display (LED)    ▪ Clip fixing
- High switching capacity

The electronic hygrotherm senses the ambient temperature and relative humidity in an enclosure with electric / electronic components and turns on a heater (or alternatively a fan) at either set point, helping prevent the formation of condensation in the enclosure. The LED integrated in the adjustment knob on the active controller is lit when the connected device is in operation.

Size chart

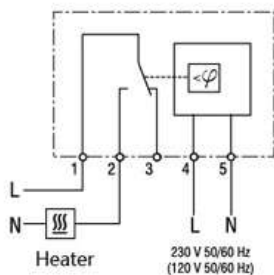
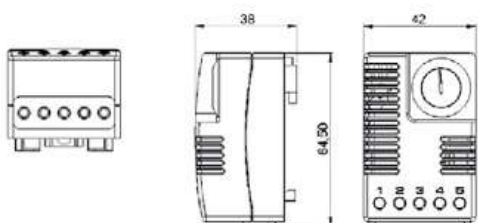

Connection diagram

Switch difference	5% RH ( $\pm 1\%$ RH tolerance) at 25°C/77°F (50% RH)
Reaction time	5 sec.
Contact type	change-over contact (relay)
Service life	> 50,000 cycles
Max. switching capacity (relay output)	240VAC, 8(1.6) A ; 120VAC, 8 (1.6)A; 100WDC at 24VDC
EMC	acc.to EN 55014-1-2, EN 61000-3-2, EN 61000-3-3
Optical indicator	LED
Connection	5-pole terminal, clamping torque 0.5Nm max.:rigid wire 2.5mm <sup>2</sup> stranded wire (with wire end ferrule) 1.5mm <sup>2</sup>
Mounting	clip for 35mm DIN rail, ( EN50022 )
Casing	UL94 V-0, light grey
Dimensions	64.5 x 42 x 38mm
Weight	approx. 70g
Fitting position	vertical
Operating / Storage temperature	0 to +60°C(+32 to +140°F) / -20 to +70°C(-4 to +158°F)
Operating / Storage humidity	max. 90 % RH (non-condensing)
Protection type	IP20

Art. No.	Operating voltage	Setting range
01245.0-00	230VAC, 50/60Hz	40 to 90% RH
01246.0-00	230VAC, 50/60Hz	65% RH pre-set
01245.9-00	120VAC, 50/60Hz	40 to 90% RH
01246.9-00	120VAC, 50/60Hz	65% RH pre-set

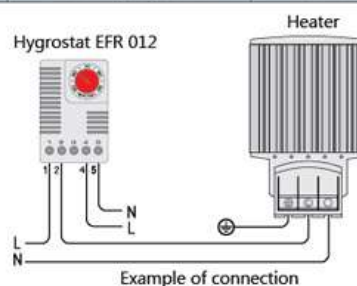

Example of connection

Art. No.	Operating voltage	Setting range	Approvals
01245.0-00	230VAC, 50/60Hz	40 to 90% RH	CE
01246.0-00	230VAC, 50/60Hz	65% RH pre-set	CE
01245.9-00	120VAC, 50/60Hz	40 to 90% RH	CE
01246.9-00	120VAC, 50/60Hz	65% RH pre-set	CE

Heater / Thermostat / Hygrostat



- Large setting range
- Optical operating display (LED)
- Change-over contact
- Small hysteresis
- Clip fixing

The electronic thermostat is used for controlling heating and cooling equipment, filter fans or signal devices. The thermostat registers the surrounding air and can switch both inductive and resistive loads via relay with change-over contact. The LED integrated in the adjustment knob is lit when the NC contact is closed (e.g. when a connected heater is operating).

Size chart

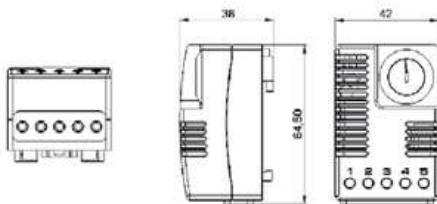

Switch difference	4K (±1K tolerance) at 20 °C/68 °F
Sensor element	NTC
Reaction time	5 sec
Contact type	change-over contact (relay)
Service life	> 50,000 cycles
Max. switching capacity (relay output)	240VAC,8(1.6)A/120VAC,8(1.6)A 100WDC at 24VDC
Max. inrush current	16AAC for 10 sec.
Optical indicator	LED
Connection	5-pole terminal, clamping torque 0.5Nm max.:rigid wire 2.5mm <sup>2</sup> stranded wire (with wire end ferrule) 1.5mm <sup>2</sup>
Mounting	clip for 35mm DIN rail, EN 60715
Casing	plastic according to UL94 V-0, light grey
Dimensions	64.5 x 42 x 38mm
Weight	approx. 70g
Fitting position	vertical
Operating / Storage temperature	-40 to +85°C (-40 to +185°F)
Operating / Storage humidity	max. 90 % RH (non-condensing)
Protection type	IP20

Art. No.	Operating voltage	Setting range
01131.0-00	230VAC,50/60Hz	-20 ~ 60°C

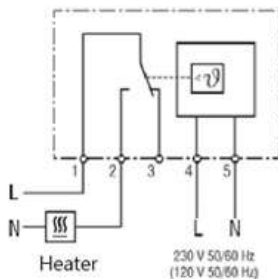

Connection diagram

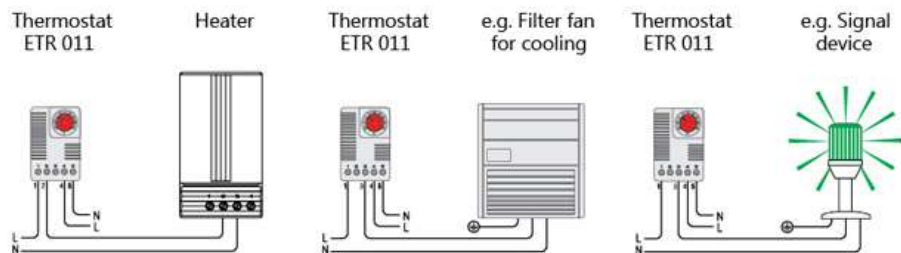

Examples of connection

Art. No.	Operating voltage	Setting range	Approvals
01131.0-00	230VAC, 50/60Hz	-20 to 60°C	CE

# Electronic Hygrotherm ETF 012



- Temperature and humidity adjustable
- High switching capacity
- Optical operating display (LED)
- Clip fixing

The electronic hygrotherm senses the ambient temperature and relative humidity in an enclosure with electric / electronic components and turns on a heater (or alternatively a fan) at either set point, helping prevent the formation of condensation in the enclosure. The LED integrated in the adjustment knob on the active controller is lit when the connected device is in operation.

Size chart

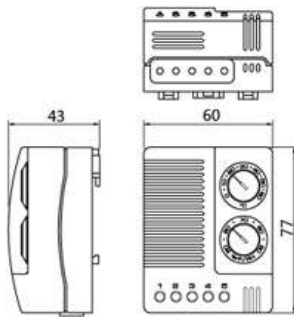

Connection diagram

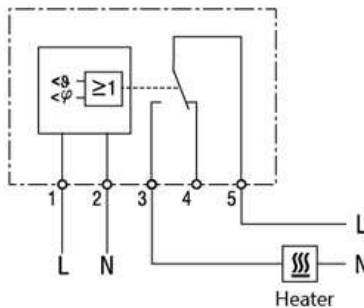

Example of connection

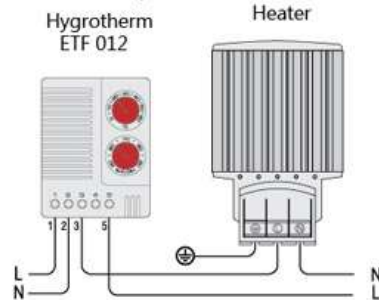

Switch difference (temperature)	2K (±1K tolerance) at 25°C/77°F (50% RH)
Switch difference (humidity)	4% RH (±1% tolerance) at 25°C/77°F (50% RH)
Reaction time (humidity)	5 sec.
Contact type	change-over contact (relay)
Contact resistance	< 10m ohm
Service life	NC: 50,000 cycles NO: 100,000 cycles
Max. Switching capacity (relay output)	NC:240VAC,6(1)A NO:120VAC,8(1.6)A
	NC:240VAC,6(1)A NO:120VAC,8(1.6)A
	100WDC at 24VDC
EMC	acc.to EN 55014-1-2, EN 61000-3-2 EN 61000-3-3
Optical indicator	LED
Connection	5-pole terminal for 2.5mm <sup>2</sup> , clamping torque 0.5Nm max, rigid wire 2.5mm <sup>2</sup> -stranded wire (with wire end ferrule) 1.5mm <sup>2</sup>
Mounting	clip for 35mm DIN rail, EN 60715
Casing	plastic according to UL94 V-0, light grey
Dimensions	77×60×43mm
Weight	approx. 0.2kg
Fitting position	vertical
Operating / Storage temperature	0 to +60°C ( +32°C to +140°F ) / -20°C to +80°C ( -4°C to +176°F )
Protection type	IP20

Heater / Thermostat / Hygrostat

Art. No.	Operating voltage	Setting range temperature	Setting range humidity	Approvals
01230.0-00	230VAC, 50/60Hz	0 to +60°C	50 to 90% RH	CE
01230.9-01	120VAC, 50/60Hz	0 to +60°C	50 to 90% RH	CE



**Features:**

- Easily mounted on 35mm DIN rails with snap on attachment per EN50022

**Product Description:**

Temperature controller for controlling cabinet heaters, filter fans, slide-in fans, heat exchangers etc.

- Locking adjusting knob grey scala
- Standard thermic reduction

Storage temperature	-20° bis + 80°C
Switching current	100-250VAC
Heating (opened con.)	10 A (2) DC 30W
Cooling (closed con.)	5 A (2) DC 30W
Switching hysteresis	Approx. 5 K (with thermic reduction approx.1K)
Contact	2 way
Connection	4 screw terminals 2,5 mm <sup>2</sup>
Sensor element	Bimetal
Service life time	> 100.000 switching cycles
Temperature control range	0...+60°C
Surface finish	Plastic light grey UL94VO
Dimension (WxHxD)	37x64x46mm
Weight	0.06 kg
Protection type	IP20

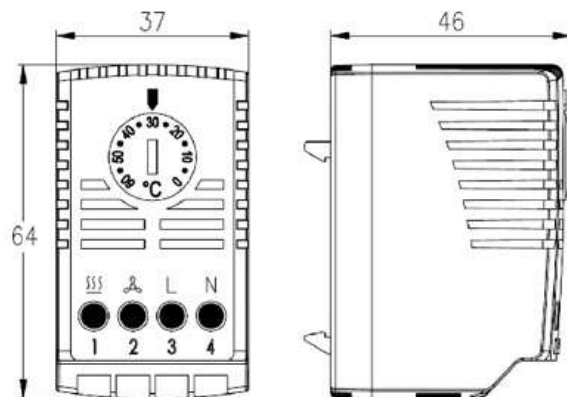
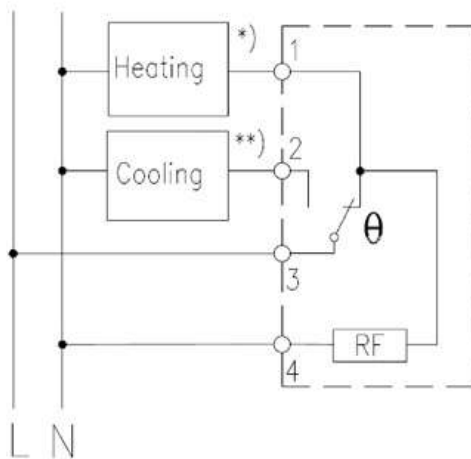

# HG140 Type Heater



- Pressure clamp connectors
- Dynamic heating up
- wide voltage range
- Temperature limiting
- Energy saving
- Clip fixing
- Quick installation

These heaters are used in enclosures where damage from condensation must be prevented or where the temperature may not fall below a minimum value. The aluminium profile heater body design has a chimney effect and distributes the heat evenly. The pressure clamp connectors save time and simplify installation.

Size chart

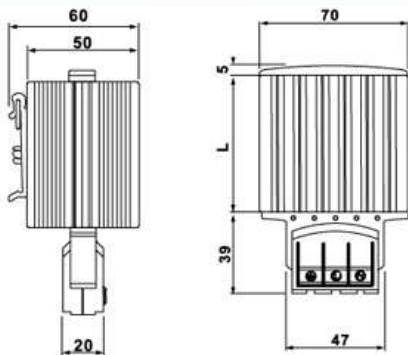

Operating voltage	120-250V AC/DC
Heating element	PTC resistor, self regulating and temperature limiting
Heater body	extruded aluminium profile, anodised
Connection casing	3 pressure clamps for stranded wire 0.5-1.5mm <sup>2</sup> (with wire and ferrule) and rigid wire 0.5-2.5mm <sup>2</sup> plastic according to UL94 V-0, black
Mounting	clip for 35mm DIN rail, EN 50022
Fitting position	vertical
Operating/Storage temperature	-45 to +70°C (-49 to +158°F)
Protection type/Protection class	IP20/I(earthed)
Certificate	CE

Operating with voltages below 140V AC/DC reduces heating performance by approx. 10%

Type	Heating capacity	Inrush current max.	Length(L) (mm)	Weight (approx)
HG 140	15W	1.5	75	0.3
HG 140	30W	3	75	0.3
HG 140	45W	3.5	75	0.3
HG 140	60W	2.5	75	0.3
HG 140	75W	4	75	0.3
HG 140	100W	4.5	145	0.5
HG 140	150W	9	145	0.5





- Screw terminal connector
- Dynamic heating up
- wide voltage range
- Temperature limiting
- With indicator showing on/off
- Energy saving
- Clip fixing
- Quick installation

These heaters are used in enclosures where damage from condensation must be prevented or where the temperature may not fall below a minimum value. The aluminium profile heater body design has a chimney effect and distributes the heat evenly. The pressure clamp connectors save time and simplify installation.

Size chart

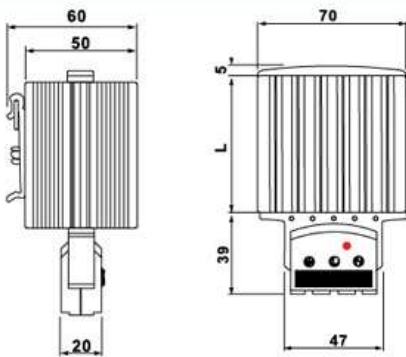

Operating voltage	120-250V AC/DC
Heating element	PTC resistor, self regulating and temperature limiting
Heater body	extruded aluminium profile, anodised
Connection casing	3 pressure clamps for stranded wire 0.5-1.5mm <sup>2</sup> (with wire and ferrule) and rigid wire 0.5-2.5mm <sup>2</sup> plastic according to UL94 V-0, black
Mounting	clip for 35mm DIN rail, EN 50022
Fitting position	vertical
Operating/Storage temperature	-45 to + 70°C (-49 to +158°F)
Protection type/Protection class	IP20/I(earthed)
Certificate	CE

Operating with voltages below 140V AC/DC reduces heating performance by approx. 10%

Type	Heating capacity	Inrush current max.	Length(L) (mm)	Weight (kg)
LK 140	15W	1.5	65	0.2
LK 140	30W	2.5	65	0.2
LK 140	45W	3	65	0.2
LK 140	60W	3.5	65	0.2
LK 140	75W	4	65	0.2
LK 140	100W	4.5	145	0.4
LK 140	150W	9	145	0.4

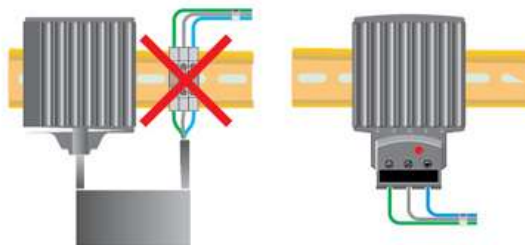

# HGL046 Type Compact Fan Heater



- Compact Design
- Clip fixing
- Long service life
- Maintenance free
- Temperature safety cut-out

Compact fan heater prevents formation of condensation. The integrated high performance axial fan provides forced air circulation and so guarantees an even temperature in enclosures. With internal terminal connector.

Size chart

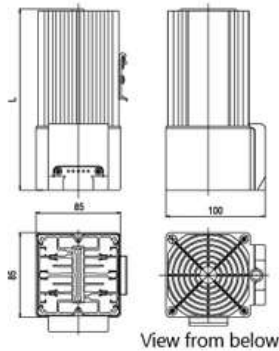

Operating voltage	230V AC 50/60Hz
Heating element	PTC resistor, self regulating and temperature limiting
Temperature safety cut-out	to protect against overheating in case of fan failure
Heater body	anodised extruded aluminium profile
Surface temperature	max. 75 °C(400W)
Axial fan, ball bearing	Airflow, free flow AC: 45m³/h (50HZ) or 54m³/h (60Hz) DC: 54m³/h service life 50 000h at 25°C (77°F)
Connection	internal connection terminal 1.5mm² with strain relief clamping torque 0.8Nm max.
Connection casing	plastic according to UL94 V-0,black
Mounting	clip for 35mm DIN rail, EN 50022
Fitting position	vertical
Operating/Storage temperature	-45 to +70 °C(-49 to +158°F)
Protection type/Protection class	IP20 / I (earthed)

Type	Operating voltage	Heating capacity	Length (L)	Weight (approx.)
HGL046-250	230VAC, 50/60HZ	250W	85x182x85mm	1.10kg
HGL046-400	230VAC, 50/60HZ	400W	85x222x85mm	1.40kg

Heater Fan Heater HGL 046 (DC 24V and 48V) with temperature safety cut-out

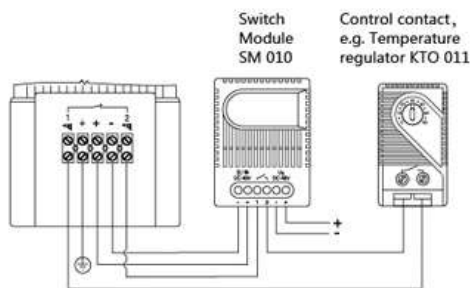

Control contact, e.g. Temperature regulator KTO 011

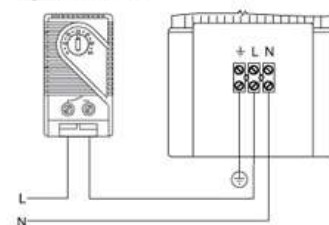

Heater Fan Heater HGL 046 (AC 230V and 120V) with temperature safety cut-out



- Compact / Flat design
- High air through-flow
- Temperature safety cut-out
- Clip fixing

Compact high-performance fan heater prevents formation of condensation and frost and provides an evenly distributed interior air temperature in enclosures with electric/electronic components. This fan heater is available without fan (HV 031) and with fan (HVL 031).

Size chart

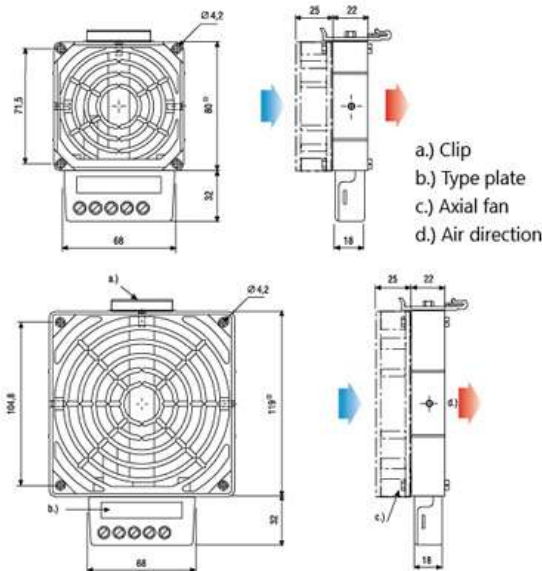

**Important!**  
Heater may only be operated together with fan. Danger of overheating!

HV 031	Heater without fan (fan mounting kit included)
HVL 031	Heater with fan
Heating element	high performance cartridge
Temperature safety cut-out	to protect against overheating in case of fan failure
Heater body	die-cast aluminium(glass bead blasted)
Connection	3-pole screw connector 2.5mm <sup>2</sup> , clamping toeque 0.8Nm max
Connection casing	plastic according to UL94 V-0, BLACK
Mounting	clip for 35mm DIN rail, EN50022
Fitting position	horizontal
Operating/Storage temperature	-45 to +70°C / (-49 to +158°F)
Protection type/Protection class	IP20/1 (earthed)
Service life	service life 50,000h at 25°C / (77°F)
Connection(axial fan)	2-pole screw connector 2.5mm <sup>2</sup> (L2/N2)

Art.no.HV 031	Art.no.HV 031	Heating capacity	Dimensions	Weight(approx.)
230vac,50/60Hz	120 vac,50/60Hz			
03100.0-00	03100.9-00	100W	80×112×22mm	0.40kg
03101.0-00	03101.9-00	150W	80×112×22mm	0.40kg
03110.0-00	03110.9-00	200W	119×151×22mm	0.50kg
03111.0-00	03111.9-00	300W	119×151×22mm	0.50kg
03112.0-00	03112.9-00	400W	119×151×22mm	0.50kg

Art.no.HVL 031	Art.no.HVL 031	Heating capacity	Airflow min	Dimensions	Weight(approx.)
230vac,50/60Hz	120 vac,50/60Hz		free flow		
03102.0-00	03102.9-00	100W	35m <sup>3</sup> /h	80×112×47mm	0.60kg
03103.0-00	03103.9-00	150W	35m <sup>3</sup> /h	80×112×47mm	0.60kg
03113.0-00	03113.9-00	200W	108m <sup>3</sup> /h	119×151×47mm	0.90kg
03114.0-00	03114.9-00	300W	108m <sup>3</sup> /h	119×151×47mm	0.90kg
03115.0-00	03115.9-00	400W	108m <sup>3</sup> /h	119×151×47mm	0.90kg

# LK143 Series Compact Fan Heater



## Connections

Pos 1 Heater, Live  
Pos 2 Neutral  
Pos 3 Fan, Live

Note: Heater must be mounted vertically with air exit at the top

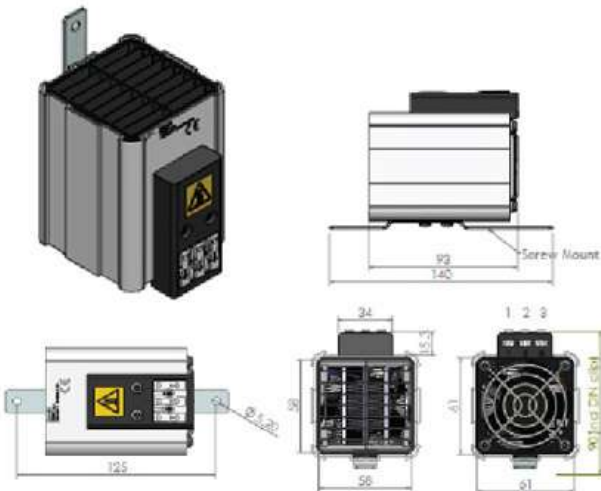

## LK143 220-240V 150W Screw Mount

60mm Axial fan PTC heating element, with cage clamp connection

Type Number	LK143
Nominal Power Output (+5/-10%) at 10°C	150W (+5/-10%)
Input Voltage	220-240 VAC
Frequency	50-60Hz
Max. body temperature (25°C Ambient)	74°C
Connection (Cage Type)	Push In
Fan Lifetime (MTTF)	329,447hrs (30°C 65%RH)
Operating & Storage Temperature	-40°C to 70°C (RH<20%)
Air Flow Rate (zero static pressure)	30m <sup>3</sup> /hr (18 CFM)
Weight	300g
Ingress Protection (EN60529)	IP20
Electrical Protection	SK II
Recommended Fuse (time Delay)	TBD
Mounting	Screw Mount

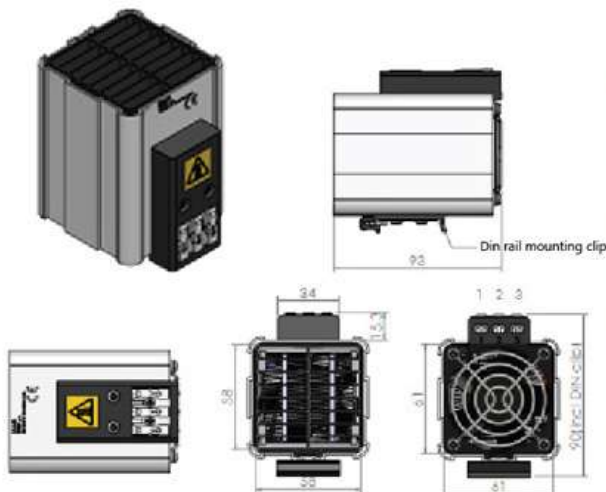

## LK143 220-240V

60mm Axial fan PTC heating element, with cage clamp connection

Type Number	LK143		
Nominal Power Output (+5/-10%) at 10°C	300W	400W	500W
Input Voltage	220-240 VAC		
Frequency	50-60Hz		
Max. body temperature (25°C Ambient)	74°C		
Connection (Cage Type)	Push In		
Fan Lifetime (MTTF)	329,447hrs (30°C 65%RH)		
Operating & Storage Temperature	-40°C to 70°C (RH<20%)		
Air Flow Rate (zero static pressure)	30m <sup>3</sup> /hr (18 CFM)		
Weight	300g		
Ingress Protection (EN60529)	IP20		
Electrical Protection	SK II		
Recommended Fuse (time Delay)	6.3A	6.3A	8A
Mounting	Aluminum DIN Clip 35mm EN50022 Compliant		



- Compact design
- Clip fixing
- Long service life
- Maintenance free

Compact fan heater prevents formation of condensation. The integrated high performance axial fan provides forced air circulation and so guarantees an even temperature in enclosure.

Features	Unit	KHL120075.0-00	KHL120100.0-00	KHL120150.0-00	KHL120230.0-00	KHL120300.0-00
Heating Capacity*	W	75	100	150	230	300
Power supply	V/Hz	Heater 110-250V AC/DC-Fan 24V AC/DC				
Max. current	A	4	4	6	6	8
Heating element type	-	PTC resistor, self regulating				
Radiator	-	Extruded aluminium profile, anodized				
Axial fan	-	Ball bearing, service life 50.000 hrs at 25°C (77°F), air flow rate 11m <sup>3</sup> /h, free flow				
		air flow rate 11m <sup>3</sup> /h, free flow				air flow rate 33m <sup>3</sup> /h, free flow
Electrical connections	-	Silicon cable, 4x0.5m <sup>2</sup> , length 400mm				
Protection class IEC	-	Class I				
Protection degree EN60529	-	IP20				
Operating temperature	°C (°F)	-20/+70 (-4/+158)				
Storage temperature	°C (°F)	-25/+70 (-13/+158)				
Mounting	-	Clip for mounting on DIN rail 35mm EN50022				
Installation position	-	Best performance in vertical installation				
Dimensions HxWxD	mm	97x40x40	97x40x40	132x40x40	142x40x40	157x40x40
Cable length	mm	400	400	400	400	400
Weight (with packaging)	kg	0.20(0.21)	0.20(0.21)	0.26(0.28)	0.28(0.30)	0.40(0.42)
Conformity	-	CE				

\*at 20°C (68°F) ambient temperature

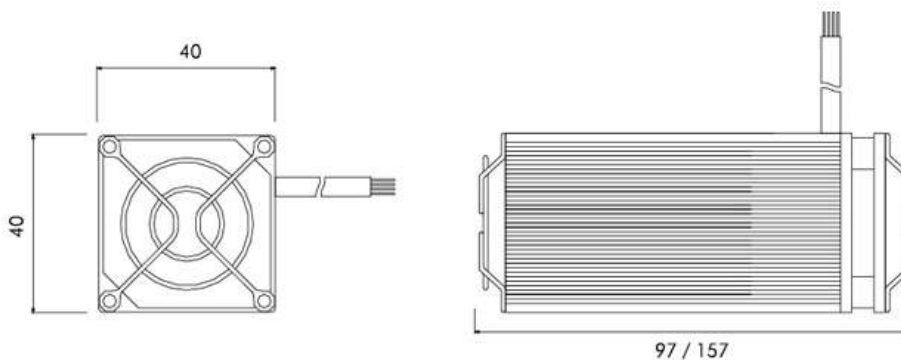

97 / 157

# Space-saving Heater KHP300(B) Series



- Compact Design
- Clip fixing
- Temperature safety cut-out
- Long service life
- Maintenance free

Technical Drawing

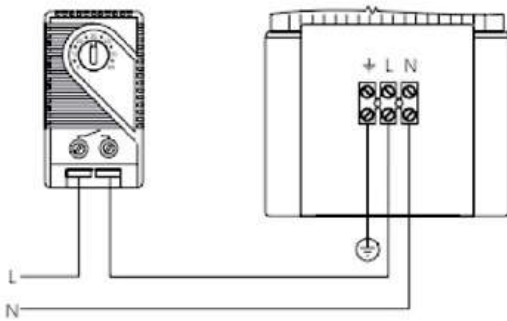

## Technical Data

KHP300	With Fan
Heating element	PTC heater PTC
Input	AC 230V 50/60Hz 300-350W
Insulating strength	2000V/0.5mA/5s
Surface Temperature	60°C (at 30°C ambient temperature)
Axial fan, ball bearing	Airflow: AC: 24m³/h (50Hz) or 31m³/h (60Hz)
RPM	2400
Heater body	Aluminium alloy castings+PPS profile
Cooling method	Natural cooling
Connection Casing	Plastic according to UL94V-0, black
Mounting	Clip for 35mm DIN rail, EN50022
Fitting position	Vertical
Operating/Storage temperature	-45 to +70°C (-49 to +158°F)
Protection type/Protection class	IP20/I(earthed)
Service life	50,000h at 25°C (77°F)

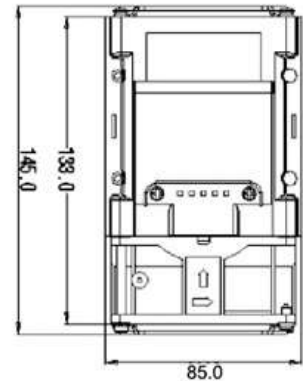
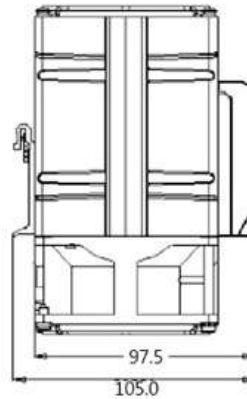
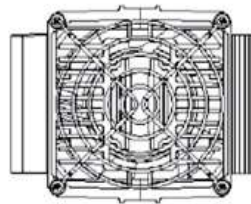
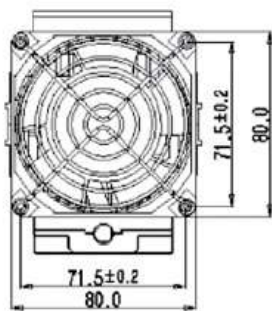

Art. No.	Operating voltage	Heating capacity
30005.0-00	230VAC, 50/60Hz	300W



- Compact Design
- Clip fixing
- Temperature safety cut-out
- Long service life
- Maintenance free

Compact fan heater prevents formation of condensation. The integrated high performance axial fan provides forced air circulation and so guarantees an even temperature in enclosure.

### Technical Data

Heating element	PTC
Temperature safety cut-out	to protect against overheating in case of fan failure
Heater body	anodised extruded aluminium profile
Axial fan, ball bearing	Airflow, free flow
	Air volume: 35m <sup>3</sup> /h
	DC: 54m <sup>3</sup> /h
	service life 50.000h at 25°C (77°F)
Connection	5-pole screw connector 2.5mm <sup>2</sup>
Mounting	clip for 35mm DIN rail, EN 50022
Fitting position	vertical
Operating temperature	-25 to +70°C (-13 to +158°F)
Storage temperature	-25 to +70°C (-13 to +158°F)
Protection class	IP20 / I(earthed)

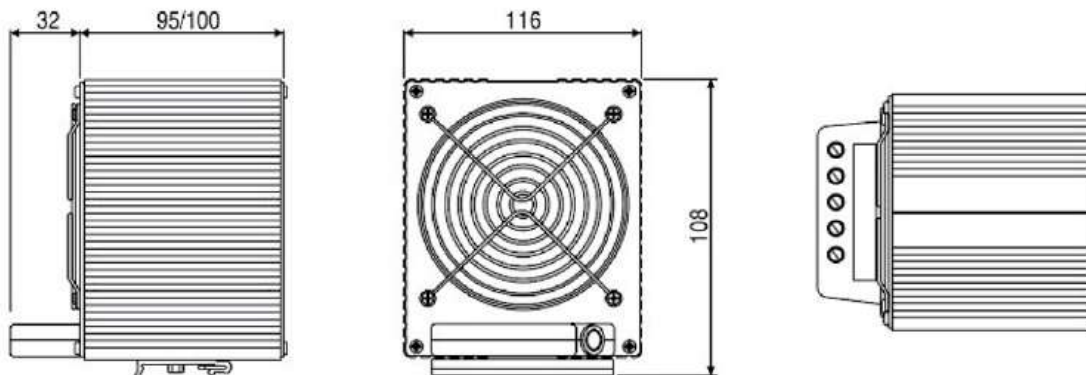

Art. No. 230VAC, 50/60Hz	Art. No. 115VAC, 50/60Hz	Heating capacity	Dimension	Weight
150.0-00	150.9-00	150W	108x116x127mm	0.6kg
200.0-00	200.9-00	200W	108x116x127mm	0.6kg
250.0-00	250.9-00	250W	108x116x127mm	0.6kg
300.0-00	300.9-00	300W	108x116x127mm	0.6kg
400.0-00	400.9-00	400W	108x116x127mm	0.6kg
650.0-00	650.9-00	650W	108x116x132mm	1.1kg

# Fan heaters 800-1500W

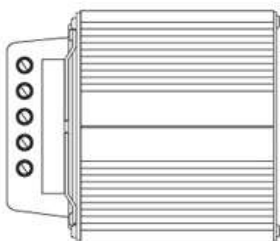
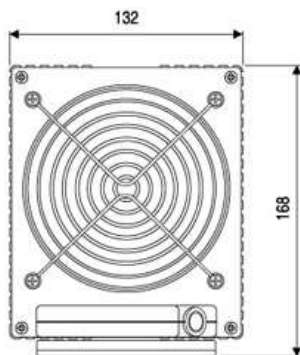
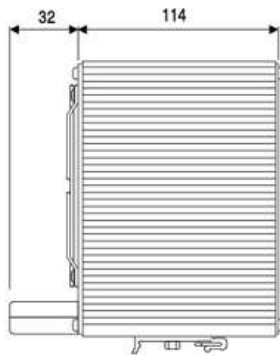

## Fan Assisted PTC Heaters

Heating Capacity		W	800W	1000W	1200W	1500W
Aticie number	230	V/HZ	800.0-00	1000.0-00	1200.0-00	1500.0-00
	110		800.9-00	1000.9-00	1200.9-00	1500.9-00
Max. current		A	8.0	9.0	12.0	13.0
Heating element			PTC			
Thermal protection			Thermal out out fuse in cose of fan failure			
Radieter			Extruded aluminium profile, anodized			
Axial fan			Ball bearing, service life 50.000 hrs at 25°C(77°F), air flow rate 35m³/h, free flow			
Electrical connections			5 screw terminals for stranded or rigid wire 2.5mm²			
Terminal block			plastic according to V-0, black			
Protection class IEC			Class°C ,Earthed			
Protection degree EN80529			IP20			
Operating/Storage temperature			-25/+70°C			
Mounting			clip for 35MM DIN rail, EN 50022			
Fitting position			vertical			
Dimensions H*W*D		mm	132×168×146			
Weight		KG	1.5			
Conformity			CE			



- Compact design
- Double insulated
- Integrated thermostat or hygrostat

The compact high performance fan heater prevents formation of condensation in enclosures and provides an evenly distributed interior air temperature in enclosures with electric/electronic components. The plastic enclosure provides double insulation and acts as protection against contact. The fan heater is available with integrated thermostat or pre-set hygrostat for temperature or humidity control. The CT 030 was designed as a stationary unit for the bottom of the enclosure. For wall fixing the fan heater CR 130 is recommended.

### Technical Drawing

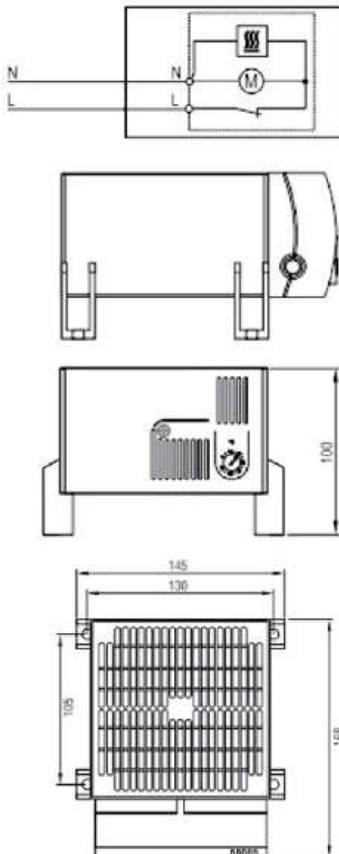

### Technical Data

Heating element	high performance cartridge
Temperature safety cut-out	to protect against overheating in case of fan failure automatic reset
Heater body	extruded alumin profile
Axial fan, ball bearing	airflow 160 m <sup>3</sup> /h, free flow
Connection	2-pole max. 2.5mm <sup>2</sup> , clamping screw with strain relief torque 0.8Nm max.
Casing	plastic according to UL94 V-0,black
Mounting	screw fixing (M5)
Fitting position	horizontal
Dimensions	168×145×100mm
Weight	approx. 1.40kg
Operating/storage temperature	-45 to +70°C (-49 to +158°F)
Protection type/Production class	IP20 / II (double insulated)

Note: other heating capacities from 200W up available on request

\* Operating temperature of heater with integrated hygrostat: 0 to +60°C (+32 to 140°F)

Art. No.	Model	Operating voltage	Heating capacity	Setting range
KCR03047.0-00	Fan Heater with thermostat	230VAC,50/60Hz	250W	0 to 60°C
KCR03047.0-02	Fan Heater with hygrostat	230VAC,50/60Hz	250W	65% RH, factory-set
KCR03047.9-00	Fan Heater with thermostat	120VAC,50/60Hz	250W	+32 to 140°F
KCR03048.0-00	Fan Heater with hygrostat	230VAC,50/60Hz	400W	0 to 60°C
KCR03048.0-02	Fan Heater with thermostat	230VAC,50/60Hz	400W	65% RH, factory-set
KCR03048.9-00	Fan Heater with hygrostat	120VAC,50/60Hz	400W	+32 to 140°F
KCR03049.0-00	Fan Heater with thermostat	230VAC,50/60Hz	600W	0 to 60°C
KCR03049.0-02	Fan Heater with hygrostat	230VAC,50/60Hz	600W	65% RH, factory-set
KCR03049.9-00	Fan Heater with thermostat	120VAC,50/60Hz	600W	+32 to 140°F
KCR03050.0-00	Fan Heater with hygrostat	230VAC,50/60Hz	800W	0 to 60°C
KCR03050.0-02	Fan Heater with thermostat	230VAC,50/60Hz	800W	65% RH, factory-set
KCR03050.9-00	Fan Heater with hygrostat	120VAC,50/60Hz	800W	+32 to 140°F
KCR03051.0-00	Fan Heater with thermostat	230VAC,50/60Hz	900W	0 to 60°C
KCR03051.0-02	Fan Heater with hygrostat	230VAC,50/60Hz	900W	65% RH, factory-set
KCR03051.9-00	Fan Heater with thermostat	120VAC,50/60Hz	900W	+32 to 140°F
KCR03052.0-00	Fan Heater with hygrostat	230VAC,50/60Hz	1000W	0 to 60°C
KCR03052.0-02	Fan Heater with thermostat	230VAC,50/60Hz	1000W	65% RH, factory-set
KCR03051.9-00	Fan Heater with hygrostat	120VAC,50/60Hz	1000W	+32 to 140°F

\*according to UL 499 in combination with UL 508A

# KCS 030 1200W Compact Heater



- Compact design
- Double insulated
- Integrated thermostat or hygrostat

The compact high performance fan heater prevents formation of condensation and provides an evenly distributed interior air temperature in enclosures with electric /electronic components. The plastic enclosure provides double insulation and acts as protection against contact. The fan heater is available with optional integrated thermostat for temperature control. The RCS 030 was designed as a stationary unit for the bottom of the enclosure. For wall fixing the fan heater RCS 130 is recommended.

## Technical Drawing

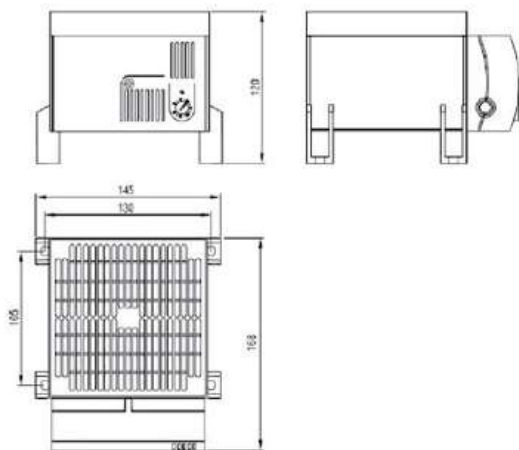

## Technical Data

Heating element	high performance cartridge
Temperature safety cut-out	to protect against overheating in case of fan failure. automatic reset
Service life	60,000h at 20 °C (68°F)
Heater body	extruded alumin profile
Axial fan, ball bearing	airflow 160 m³/h, free flow
Connection	2-pole max. 2.5mm², clamping screw with strain relief torque 0.8Nm max.
Casing	plastic according to UL94 V-0, black
Mounting	screw fixing (M5)
Fitting position	horizontal
Dimensions	168×145×100mm
Weight	approx. 1.20kg
Operating/storage temperature	-45 to +70 °C (-49 to +158°F)
Protection type/Production class	IP20 / II (double insulated)

Heating Performance/Ambient Temperature  
CS 030

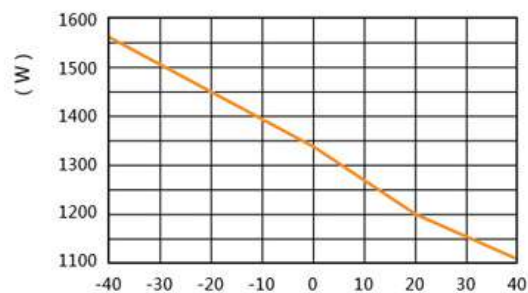

Art. No.	Model	Operating voltage	Heating capacity	Inrush current max.	Setting range
KCS03060.0-00	Fan Heater with thermostat	230VAC, 50/60Hz	1200W	13A	0 to +60°C
KCS03060.0-01	Fan Heater without thermostat	230VAC, 50/60Hz	1200W	13A	-
KCS03060.9-00	Fan Heater with thermostat	120VAC, 50/60Hz	1200W	16A	+30 to +140°F
KCS03060.9-01	Fan Heater without thermostat	120VAC, 50/60Hz	1200W	16A	-



DA 084



DA 284

- High degree of protection
- Easy to install

It has become more and more important to provide a protected enclosure environment for valuable and crucial electrical and electronic components. In a tightly closed enclosure, pressure differentials can occur during extreme temperature variations. The specially designed pressure compensation device DA 084 permits a controlled change in pressure and avoids the entering of dust and water. The pressure compensation device is suitable for the use in enclosures and housings in accordance with DIN EN 62208.

Mounting	PG 29 thread with union nut
Material	plastic according to UL94 V-0
Air interface	approx. 7cm <sup>2</sup>
Dimensions	φ 65.5 x 30.5mm
Operating / Storage temperature	-45 to +70°C (-49 to +158°F)
Art. No.	DA 084
Description	mount pressure compensation device
Protection type	IP45
1 packing unit	2 pieces
Weight	31g/pieces

#### Installation

Make cut-out φ 37 mm in enclosure wall and mount pressure compensation device with nut. Please make sure that the sealing gasket is put in place on the outer side panel of the enclosure. For optimal pressure compensation we recommend to use two devices on opposite sides towards the top of the enclosure.

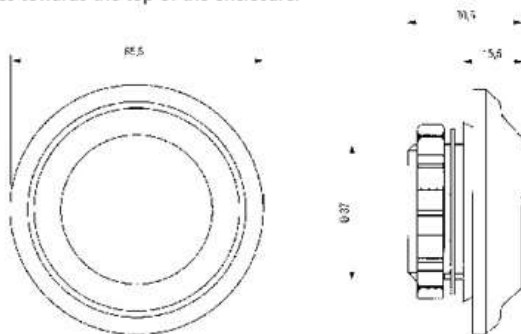

Art. No.	Protection type	1 packing unit	Weight (approx.)
08400.0-04	IP55	2 pieces	62g (31g/piece)

- High degree of protection
- Waterproof membrane
- Easy to install

Pressure differentials in enclosures with a high degree of protection are a result of internal and external temperature changes. In the case of negative pressure or partial vacuum, dust and humidity can enter the enclosure through the door seal. When the air inside the enclosure cools down, condensation may occur because the humidity cannot escape the enclosure. The easy-to-install pressure compensation device DA 284 provides compensation of pressure at a protection degree of IP66. Even with a slight overpressure, a waterproof membrane inside the plug allows the humidity to escape whilst blocking water and dirt from entering the enclosure.

Mounting	thread M40 x 1.5 with nut
Torque	5Nm (max. 10Nm)
Depth in enclosure	approx. 16mm
Sealing	sealing gasket NBR
Filter	waterproof membrane
Air permeability	1200/h at a pressure difference of min. 70mbar
Dimensions	Ø 60 x 37mm
Fitting position	variable
Operating/Storage temperature	-35 to +70°C (-31 to +158°F)

#### Installation

Make cut-out Ø 40.5+0,5mm in enclosure wall and mount pressure compensation device with nut. Please make sure that the sealing gasket is put in place on the outer side panel of the enclosure. For optimal pressure compensation we recommend to use two devices on opposite sides towards the top of the enclosure.

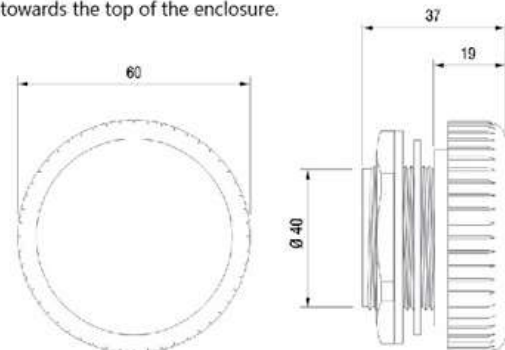

Art. No.	Protection type	1 packing unit	Weight (approx.)
28400.0-00	IP66/IPX9K	2 pieces	90g (45g/piece)

## 80×80×38mm



Motor Structure	Shaded pole motor.
Safety	Impedance Protected
Operation System	Dual high Precision ball bearings. (single sleeve bearing)
Allowable Ambient Temperature Range	(under unconcretionary condition) -20°C~+65°C(ball bearing) , -10°C~+45°C.(Sleeve bearing)
Insulation	B Class
Protection Grade	IP34

Type	F2E-80S/B-230	F2E-80S/B-115
Bearing	Sleeve/Ball	Sleeve/Ball
Voltage(V)	220/230	110/115
Frequency(Hz)	50/60	50/60
Current(A)	0.06/0.07	0.13/0.15
Power(w)	15/12	15/12
Speed(RPM)	2600/3000	2600/3000
Wind volume	45/55	45/55
Noise dB(A)	29/35	29/35
Weight(g)	335g	335g

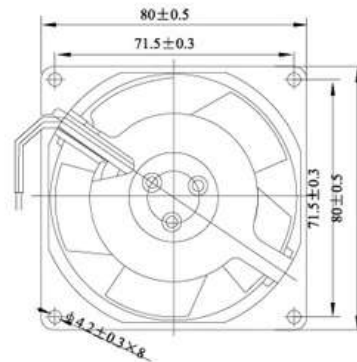
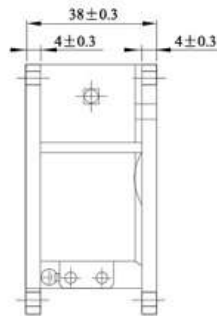

## 92×92×25mm



Motor Structure	Shaded pole motor.
Safety	Impedance Protected
Operation System	Dual high Precision ball bearings. (single sleeve bearing)
Allowable Ambient Temperature Range	(under unconcretionary condition) -20°C~+65°C(ball bearing) , -10°C~+45°C.(Sleeve bearing)
Insulation	B Class
Protection Grade	IP34

Type	F2E-92S/B-230	F2E-92S/B-115
Bearing	Sleeve/Ball	Sleeve/Ball
Voltage(V)	220/230	110/115
Frequency(Hz)	50/60	50/60
Current(A)	0.07/0.08	0.12/0.14
Power(w)	13.2/15.4	13.2/15.4
Speed(RPM)	2200/2600	2200/2600
Wind volume	60/68	60/68
Noise dB(A)	29/35	29/35
Weight(g)	255g	255g

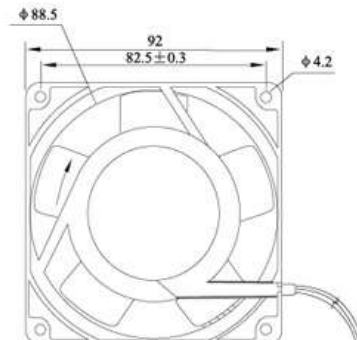

120×120×38mm



Motor Structure	Shaded pole motor.
Safety	Impedance Protected
Operation System	Dual high Precision ball bearings. (single sleeve bearing)
Allowable Ambient Temperature Range	(under unconcretionary condition) -20°C~+65°C(ball bearing) , -10°C~+45°C.(Sleeve bearing)
Insulation	B Class
Protection Grade	IP34

Type	F2E-120S/B-230	F2E-120S/B-115
Bearing	Sleeve/Ball	Sleeve/Ball
Voltage(V)	220/230	110/115
Frequency(Hz)	50/60	50/60
Current(A)	0.12/0.10	0.24/0.20
Power(w)	19/14	18/15
Speed(RPM)	2500/2700	2500/2800
Wind volume	145/160m³/h	145/170m³/h
Noise dB(A)	34/37	34/37
Weight(g)	530g	510g

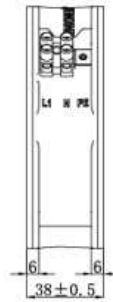
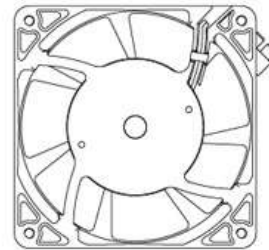
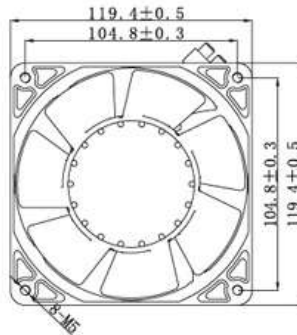

Φ150×51mm



Motor Structure	Shaded pole motor.
Safety	Impedance Protected
Operation System	Dual high Precision ball bearings. (single sleeve bearing)
Allowable Ambient Temperature Range	(under unconcretionary condition) -20°C~+65°C(ball bearing) , -10°C~+45°C.(Sleeve bearing)
Insulation	B Class
Protection Grade	IP34

Type	F2E-150S/B-230	F2E-150S/B-115
Bearing	Sleeve/Ball	Sleeve/Ball
Voltage(V)	220/230	110/115
Frequency(Hz)	50/60	50/60
Current(A)	0.19/0.17	0.48/0.46
Power(w)	38/36	41/38
Speed(RPM)	2500/2800	2500/2800
Wind volume	402/460m³/h	402/460m³/h
Noise dB(A)	50	50
Weight(g)	900g	880g

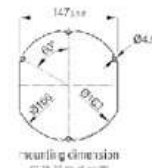
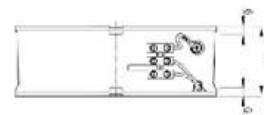
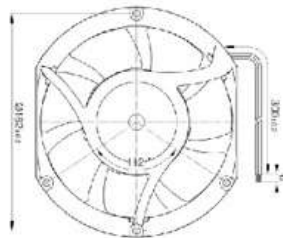
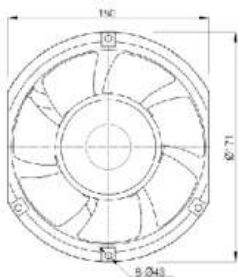

## 80×80×38mm



Metal Blades

Size	80x80x38mm
Airflow	42-54m <sup>3</sup> /hr 25-33CFM
Weight	403g
Noise	28-36dBA
Impeller	Metal
Frame	Aluminum Alloy
Terminals	0.5mm
Lead Wire	Teflon 22#UL 1332(Optional)
Motor	Shaded Pole And External Rotor Induction Motor
Operating Temperature	-10°C~+105°C

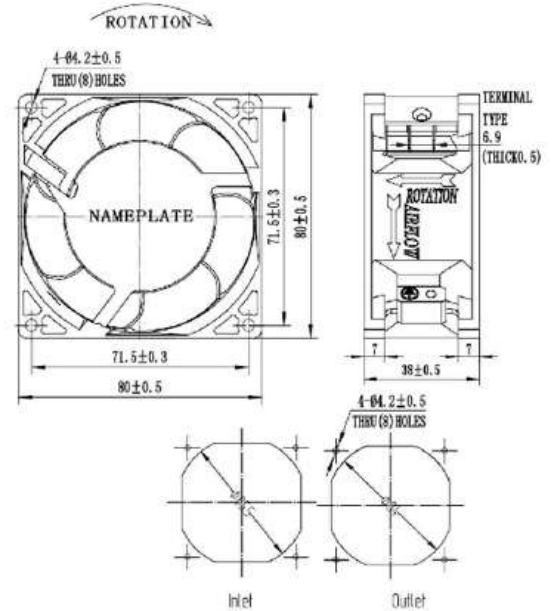

Model	Bearing System	Voltage VAC	Freq. Hz	Current A	Power W	Speed RPM	Noise dBA	Air Flow		Phase	Capacitor
								M <sup>3</sup> /hr	CFM		
FL8038HA <sub>1</sub> B-7P	Ball	100/125	50/60	0.18	17/14	2700/3100	30/36	44/54	28/33	1	/
FL8038HA <sub>2</sub> B-7P		200/240	50/60	0.1	17/14	2700/3100	30/36	44/54	28/33	1	/
FL8038MA <sub>1</sub> B-7P		100/125	50/60	0.12	11	2300/2700	28/30	42/49	25/29	1	/
FL8038MA <sub>2</sub> B-7P		200/240	50/60	0.07	11	2300/2700	28/30	42/49	25/29	1	/

Multipane fan

## 92×92×25mm



Metal Blades

Size	92x92x38mm
Airflow	71-91m <sup>3</sup> /hr 42-54CFM
Weight	480g
Noise	35-40dBA
Impeller	Metal
Frame	Aluminum Alloy
Terminals	0.5mm
Lead Wire	Teflon 22#UL 1332(Optional)
Motor	Shaded Pole And External Rotor Induction Motor
Operating Temperature	-10°C~+105°C

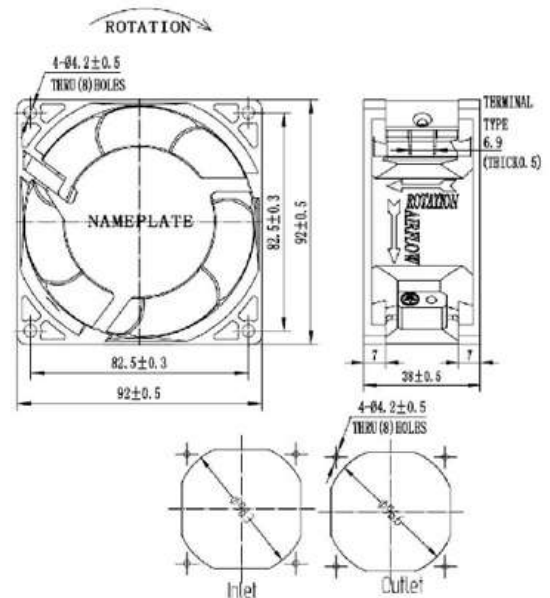

Model	Bearing System	Voltage VAC	Freq. Hz	Current A	Power W	Speed RPM	Noise dBA	Air Flow		Phase	Capacitor
								M <sup>3</sup> /hr	CFM		
FL9238HA <sub>1</sub> B-7P	Ball	100/125	50/60	0.18	17/14	2600/3000	38/40	78/91	46/54	1	/
FL9238HA <sub>2</sub> B-7P		200/240	50/60	0.1	17/14	2600/3000	38/40	78/91	46/54	1	/
FL9238MA <sub>1</sub> B-7P		100/125	50/60	0.12	11	2300/2700	35/40	71/85	42/50	1	/
FL9238MA <sub>2</sub> B-7P		200/240	50/60	0.07	11	2300/2700	35/40	71/85	42/50	1	/

120×120×38mm



Metal Blades

Size	120x120x38mm
Airflow	134-204m <sup>3</sup> /hr 79-120CFM
Weight	600g
Noise	39-50dBA
Impeller	Metal
Frame	Aluminum Alloy
Terminals	0.5mm
Lead Wire	Teflon 22#UL 1332(Optional)
Motor	Shaded Pole And External Rotor Induction Motor
Operating Temperature	-10°C~+105°C

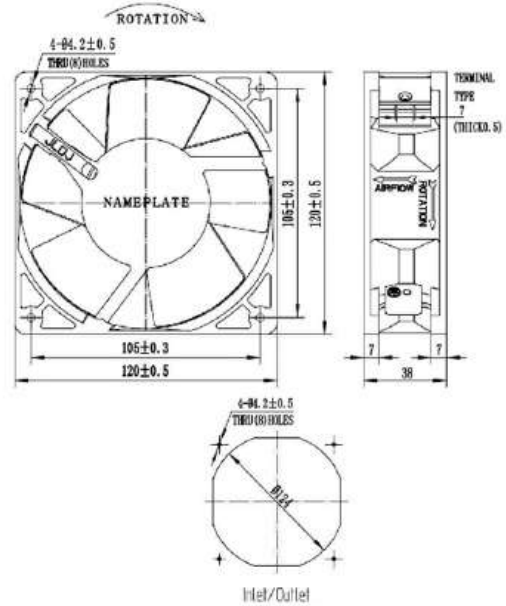

Model	Bearing System	Voltage VAC	Freq. Hz	Current A	Power W	Speed RPM	Noise dBA	Air Flow		Phase	Capacitor
								M <sup>3</sup> /hr	CFM		
FL12038HA <sub>1</sub> B	Ball	100/125	50/60	0.21	21	2600/3000	46/50	180/204	106/120	1	/
FL12038HA <sub>2</sub> B		200/240	50/60	0.11	19	2600/3000	46/50	180/204	106/120	1	/
FL12038MA <sub>1</sub> B		100/125	50/60	0.21	17	2000/2200	39/41	134/149	79/87	1	/
FL12038MA <sub>2</sub> B		200/240	50/60	0.10	16	2000/2200	39/41	134/149	79/87	1	/

172×150×38mm



Metal Blades

Size	172x150x38mm
Airflow	348-390m <sup>3</sup> /hr 205-230CFM
Weight	860g
Noise	56-59dBA
Impeller	Metal
Frame	Aluminum Alloy
Terminals	0.5mm
Lead Wire	Teflon 22#UL 1332(Optional)
Motor	Capacitor-Run And External Rotor Induction Motor
Operating Temperature	-10°C~+105°C

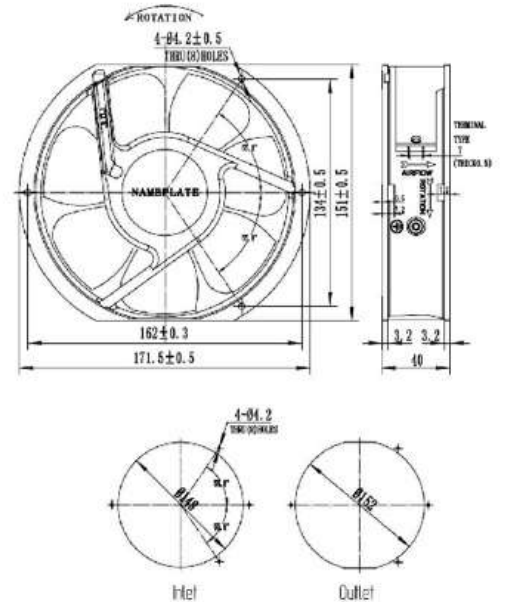

Model	Bearing System	Voltage VAC	Freq. Hz	Current A	Power W	Speed RPM	Noise dBA	Air Flow		Phase	Capacitor
								M <sup>3</sup> /hr	CFM		
FL17040HA <sub>1</sub> B	Ball	100/125	50/60	0.2/0.2	24/24	2700/3200	56/59	348/390	205/230	1	3.3uf/250v
FL17040HA <sub>2</sub> B		200/240	50/60	0.1/0.1	24/24	2700/3200	56/59	348/390	205/230	1	1uf/630v

172×150×51mm



Metal Blades

Size	172x150x51mm
Airflow	210-390m <sup>3</sup> /hr 205-230CFM
Weight	900g
Noise	56-59dBA
Impeller	Metal
Frame	Aluminum Alloy
Terminals	0.5mm
Lead Wire	Teflon 22#UL 1332(Optional)
Motor	Capacitor-Run And External Rotor Induction Motor
Operating Temperature	-10°C~+105°C

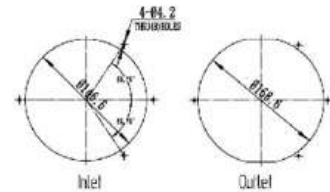
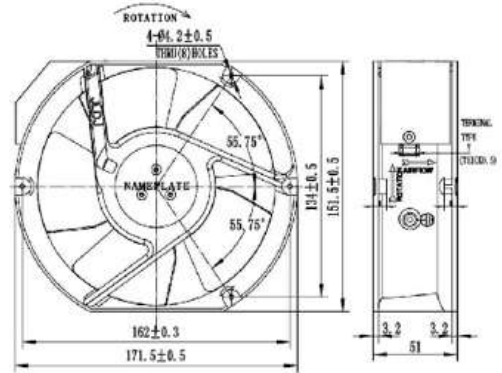

Model	Bearing System	Voltage VAC	Freq. Hz	Current A	Power W	Speed RPM	Noise dBA	Air Flow		Phase	Capacitor
								M <sup>3</sup> /hr	CFM		
FL17050HA <sub>1</sub> B	Ball	100/125	50/60	0.38/0.34	37/35	2700/3200	54/57	357/419	210/247	1	3.3uf/250v
FL17050HA <sub>2</sub> B		200/240	50/60	0.13/0.15	29/33	2700/3200	54/57	357/419	210/247	1	1uf/630v

Multiplane fan

172×162×51mm



Metal Blades

Motor Structure	Cage type structure motor.
Safety	Impedance Protected
Operation System	Dual high Precision ball bearings. (single sleeve bearing)
Allowable Ambient Temperature Range	(under unconcretionary condition) -20°C~+65°C(ball bearing) , -10°C~+45°C.(Sleeve bearing)
Insulation	B Class
Protection Grade	IP34

Type	F2E-162B-230	F2E-162B-115
Bearing	Ball	Ball
Voltage(V)	220/230	110/115
Frequency(Hz)	50/60	50/60
Current(A)	0.20/0.26	0.42/0.51
Power(w)	53/43	40/35
Speed(RPM)	2700/3000	2700/3000
Wind volume	325/380	325/380
Noise dB(A)	48/52	48/52
Weight(g)	1100g	1100g

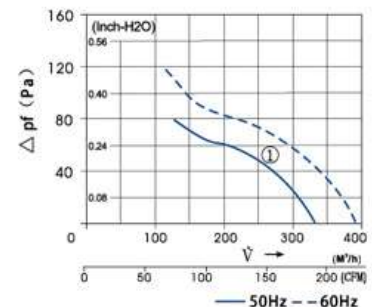
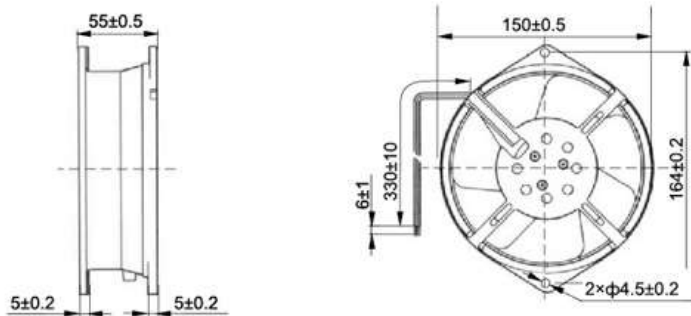

Φ220×80mm



Metal Blades

Size	Φ220x80mm
Airflow	849-925m <sup>3</sup> /hr 500-545CFM
Weight	2000g
Noise	59-61dBA
Impeller	Metal
Frame	Aluminum Alloy
Terminals	0.5mm
Lead Wire	Teflon 22#UL 1332(Optional)
Motor	Capacitor-Run And External Rotor Induction Motor
Operating Temperature	-10°C~+105°C

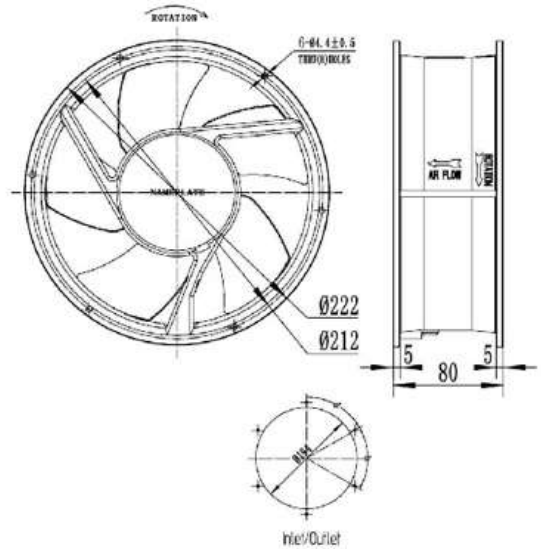

Model	Bearing System	Voltage VAC	Freq. Hz	Current A	Power W	Speed RPM	Noise dBA	Air Flow		Phase	Capacitor
								M <sup>3</sup> /hr	CFM		
FL22080HA <sub>1</sub> B-C	Ball	100/125	50/60	0.58/0.65	67/77	2600/2800	59/61	849/925	500/545	1	4.0uf/250v
FL22080HA <sub>2</sub> B-C		200/240	50/60	0.28/0.35	62/80	2600/2800	59/61	849/925	500/545	1	2uf/630v
FL22080HA <sub>3</sub> B		380/420	50/60	0.25	65	2600/2800	59/61	849/925	500/545	3	/
FL22080HA <sub>6</sub> B-C		380/420	50/60	0.25	65	2600/2800	59/61	849/925	500/545	1	1uf/630v

Φ254×89mm



Metal Blades

Size	Φ254x89mm
Airflow	1392-1528m <sup>3</sup> /hr 800-900CFM
Weight	2600g
Noise	59-61dBA
Impeller	Metal
Frame	Aluminum Alloy
Terminals	0.5mm
Lead Wire	Teflon 22#UL 1332(Optional)
Motor	Capacitor-Run And External Rotor Induction Motor
Operating Temperature	-10°C~+105°C

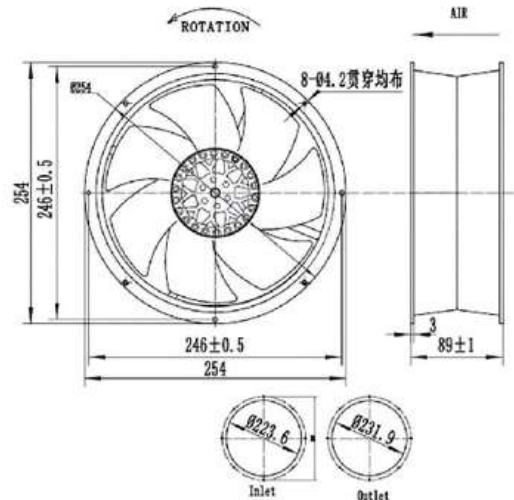

Model	Bearing System	Voltage VAC	Freq. Hz	Current A	Power W	Speed RPM	Noise dBA	Air Flow		Phase	Capacitor
								M <sup>3</sup> /hr	CFM		
FL25489HA <sub>1</sub> B-C-7P	Ball	100/125	50/60	0.98/1.15	67/77	2700/3100	59/61	1392/1528	500/545	1	4.0uf/250v
FL25489HA <sub>2</sub> B-C-7P		200/240	50/60	0.5/0.65	62/80	2700/3100	59/61	1392/1528	500/545	1	2.2uf/400v
FL25489HA <sub>3</sub> B-7P		380/420	50/60	0.25	65	2700/3100	59/61	1392/1528	500/545	3	/
FL25489HA <sub>6</sub> B-C-7P		380/420	50/60	0.25	65	2700/3100	59/61	1392/1528	500/545	1	1uf/630v

## 260×225×80mm



Metal Blades

Motor Structure	Cage type structure motor.
Safety	Impedance Protected
Operation System	Dual high Precision ball bearings. (single sleeve bearing)
Allowable Ambient Temperature Range	(under unconcretionary condition) -20°C~+65°C(ball bearing) , -10°C~+45°C.(Sleeve bearing)
Insulation	B Class
Protection Grade	IP34

Type	F2E-260B-230	F2E-260B-115
Bearing	Ball	Ball
Voltage(V)	220/230	110/115
Frequency(Hz)	50/60	50/60
Current(A)	0.34/0.29	0.63/0.61
Power(w)	63/79	61/71
Speed(RPM)	2450/2700	2500/2750
Wind volume	915/1010	925/1030
Noise dB(A)	59/61	59/61
Weight(g)	2200g	2200g

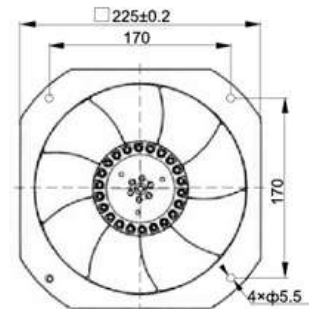
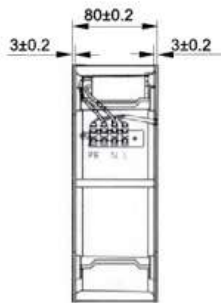

## 320×280×80mm



Metal Blades

Motor Structure	Cage type structure motor.
Safety	Impedance Protected
Operation System	Dual high Precision ball bearings. (single sleeve bearing)
Allowable Ambient Temperature Range	(under unconcretionary condition) -20°C~+65°C(ball bearing) , -10°C~+45°C.(Sleeve bearing)
Insulation	B Class
Protection Grade	IP34

Type	F2E-320B-230	F2E-320B-115
Bearing	Ball	Ball
Voltage(V)	220/230	110/115
Frequency(Hz)	50/60	50/60
Current(A)	0.46/0.60	0.95/1.20
Power(w)	140/100	140/100
Speed(RPM)	2500/2650	2480/2600
Wind volume	1800/1950	1800/1950
Noise dB(A)	68/70	68/70
Weight(g)	2900g	2900g

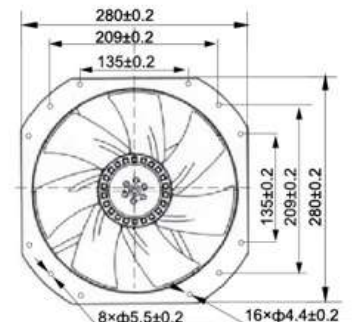
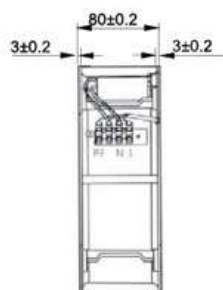

205×205×72mm



Metal Blades

Size	205x205x72mm
Airflow	905-1248m <sup>3</sup> /hr 533-735CFM
Weight	2100g
Noise	61-68dBA
Impeller	Metal
Frame	Aluminum Alloy
Terminals	0.5mm
Lead Wire	Teflon 22#UL 1332(Optional)
Motor	Capacitor-Run Induction Motor
Operating Temperature	-10°C~+65°C

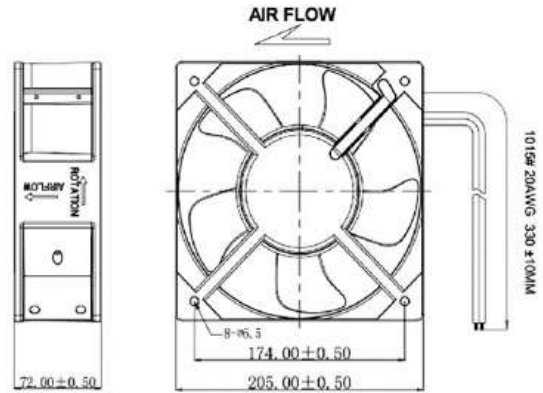

Model	Bearing System	Voltage VAC	Freq. Hz	Current A	Power W	Speed RPM	Noise dBA	Air Flow		Phase	Capacitor
								M <sup>3</sup> /hr	CFM		
FL20572HA <sub>1</sub> B-C	Ball	100/125	50/60	0.8/0.9	88/98	2850/3250	61/68	905/1248	533/735	1	10uf/250v
FL20572HA <sub>2</sub> B-C		200/240	50/60	0.35/0.45	68/78	2850/3250	61/68	905/1248	533/735	1	5uf/500v

Φ 200×60mm



Metal Blades

Size	Φ200x60mm
Airflow	730-824m <sup>3</sup> /hr 430-485CFM
Weight	1250g
Noise	55-67dBA
Impeller	Metal
Frame	Aluminum Alloy
Terminals	0.5mm
Lead Wire	Teflon 22#UL 1332(Optional)
Motor	Capacitor-Run Induction Motor
Operating Temperature	-10°C~+65°C

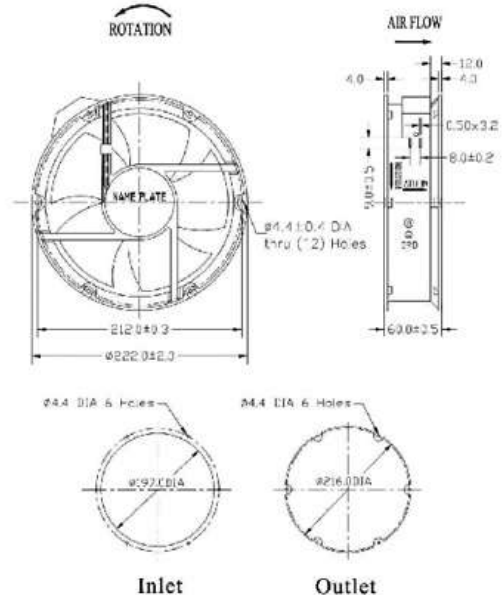

Model	Bearing System	Voltage VAC	Freq. Hz	Current A	Power W	Speed RPM	Noise dBA	Air Flow		Phase	Capacitor
								M <sup>3</sup> /hr	CFM		
FL22060HA <sub>1</sub> B-C	Ball	100/125	50/60	0.42/0.46	50/60	2800/3100	55/67	730/824	430/485	1	3.3uf/630v
FL22060HA <sub>2</sub> B-C		200/240	50/60	0.25/0.26	50/60	2800/3100	55/67	730/824	430/485	1	1.8uf/630v

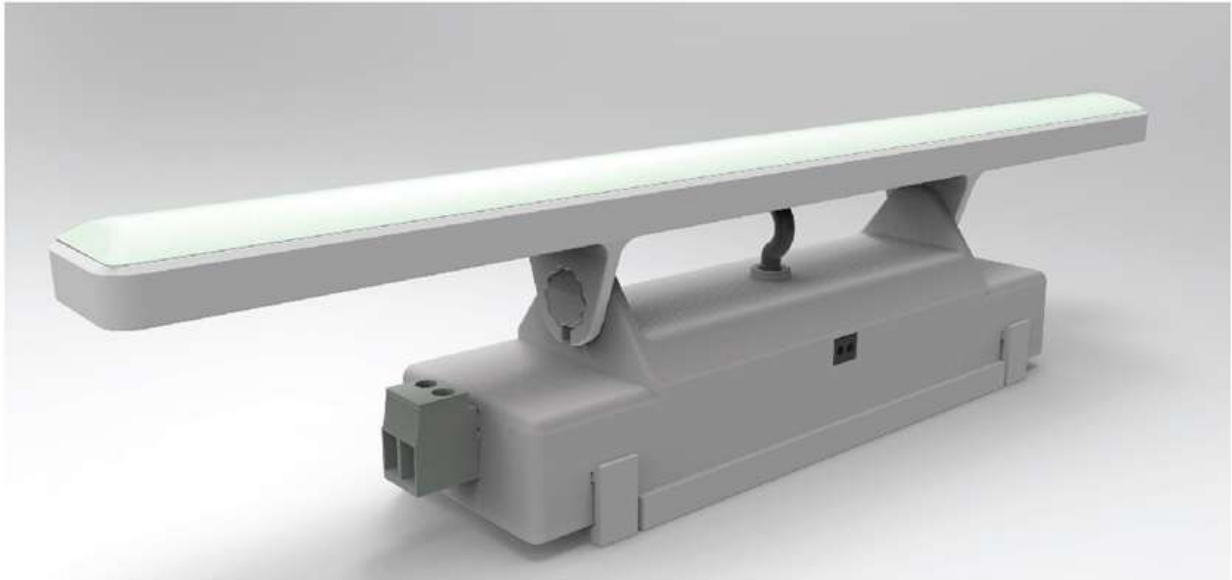

## Application

LK12-W Series LED light is designed for instrument cabinet illumination of various switchgear, built in infrared sensor switch, and simplify the user's application design.

## Features and advantage

- Built in infrared sensor switch, the user do not install additional switch.
- Economize on energy, In the case of illuminate effect same alike the traditional light, economizing on energy is 75% above.
- Life span is long, the LED light source, someone call it the longevity light, meaning to extinguish never. It's the solid cold light source, adopt a special electric circuit design, the life span can reach to for 100,000 hours, comparing traditional light source life span to grow 1000% above.
- The environmental protection performance is better, without ultraviolet ray and infrared rays in the spectrum, without calories and radiate, the dizzy light is small, and the castoff can recover, without pollution and do not contain the mercury chemical Element. The cold light source, can be touched, belong to typical model of the green illuminate light source.
- Special circuit design, if anyone LED is bad, it isn't without influence to normal illumination of others LED.
- Special structure design, light body position can be adjusted, that solves the problem of less illumination angle of LED.

## Technique parameters

Power supply	AC(50/60Hz)/DC (80-265V), or other voltage customer demand.
Average illuminance at 300mm from lamp	>300lx
Color rendering index Ra	> 85
Switch	built in infrared switch, active distance 20~80mm
Terminal	screw terminal, 0.5mm <sup>2</sup> ~2.5mm <sup>2</sup>
Working environment temperature	-25℃~+55℃
Fix method	Two hole fixation
Color of the light	white
Protection class	IP20
Withstand voltage	AC2500V, 1Min
luminescence component	LED
Rated humidity	25%~95%
Life span	More than 100,000hours
Power	6W



### Models explanation

LK 12 - W - □

Voltage code A: AC(50/60Hz)/DC (80-265V), C: DC48V, D: DC24V

Light color: White

Design number

### Dimension

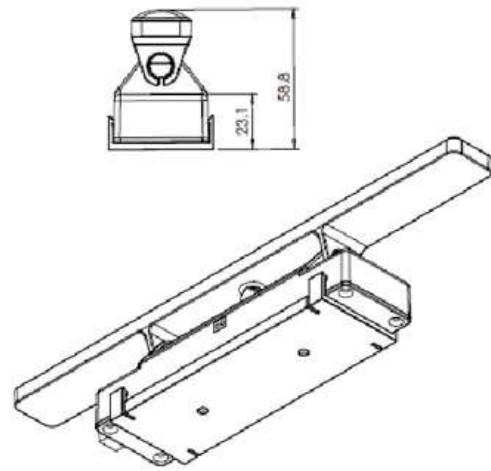
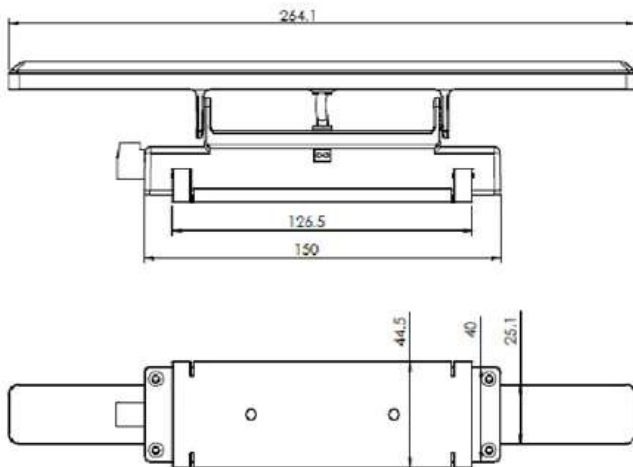

### Installation

Installation: first fix the fixed plate on the position that the lamp need to be install , and then push the lamp into the fixed plate to complete the installation.

Remove: use a screwdriver to remove 4 bayonet from the slot of the fixed plate, and then extract the lamp to complete the disassembly.

Fixed screw: Slotted countersunk flat head screws (common head style), M4\*8, ISO 2009

The following drawing specify a fixed plate size , please use this drawing to design the mounting hole.

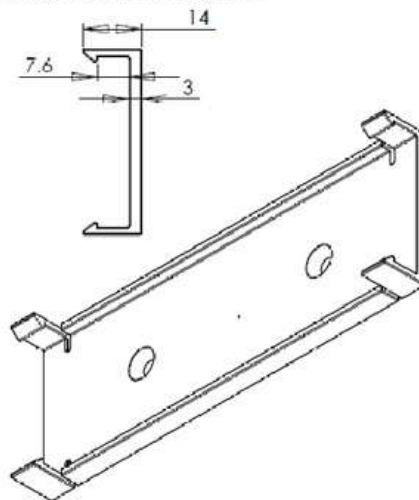
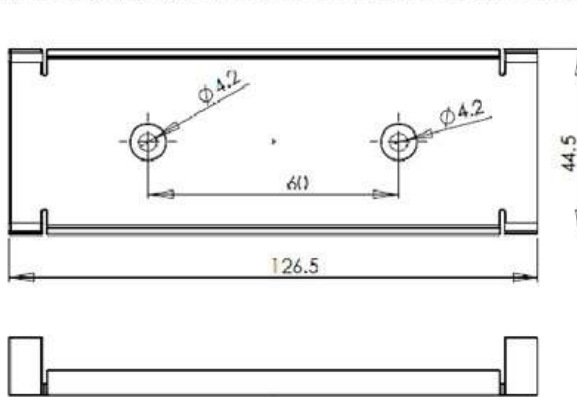

Note: Infrared sensor should be parallel to the reflecting surface.



Infrared sensor





## Application

LK13-W Series LED light is designed for instrument cabinet illumination of various switchgear, built in switch , and simplify the user's application design.

## Features and advantage

- Built in switch, the user do not install additional switch.
- Economize on energy, In the case of Illuminate effect same alike the traditional light, economizing on energy is 75% above.
- Life span is long, the LED light source, someone call it the longevity light, meaning to extinguish never. It's the solid cold light source, adopt a special electric circuit design, the life span can reach to for 100,000 hours, comparing traditional light source life span to grow 1000% above.
- The environmental protection performance is better, without ultraviolet ray and infrared rays in the spectrum, without calories and radiate, the dizzy light is small, and the castoff can recover, without pollution and do not contain the mercury chemical Element. The cold light source, can be touched, belong to typical model of the green illuminate light source.
- Special circuit design, if anyone LED is bad, it isn't without influence to normal illumination of others LED.
- Special structure design, light body position can be adjusted, that solves the problem of less illumination angle of LED.

## Technique parameters

Power supply	AC(50/60Hz)/DC (80-265V) , or other voltage customer demand.
Average illuminance at 300mm from lamp	>300lx
Color rendering index Ra	> 85
Switch	built in switch
Terminal	screw terminal, 0.5mm <sup>2</sup> ~2.5mm <sup>2</sup>
Working environment temperature	-25℃ ~+55 ℃
Fix method	Two hole fixation,
Color of the light	white
Protection class	IP20
Withstand voltage	AC2500V, 1Min
luminescence component	LED
Rated humidity	25% ~95%
Life span	More than 100,000hours
Power	6W



### Models explanation

LK 13 - W - □

Voltage code A: AC(50/60Hz)/DC (80-265V), C: DC48V, D: DC24V

Light color: White

Design number

### Dimension

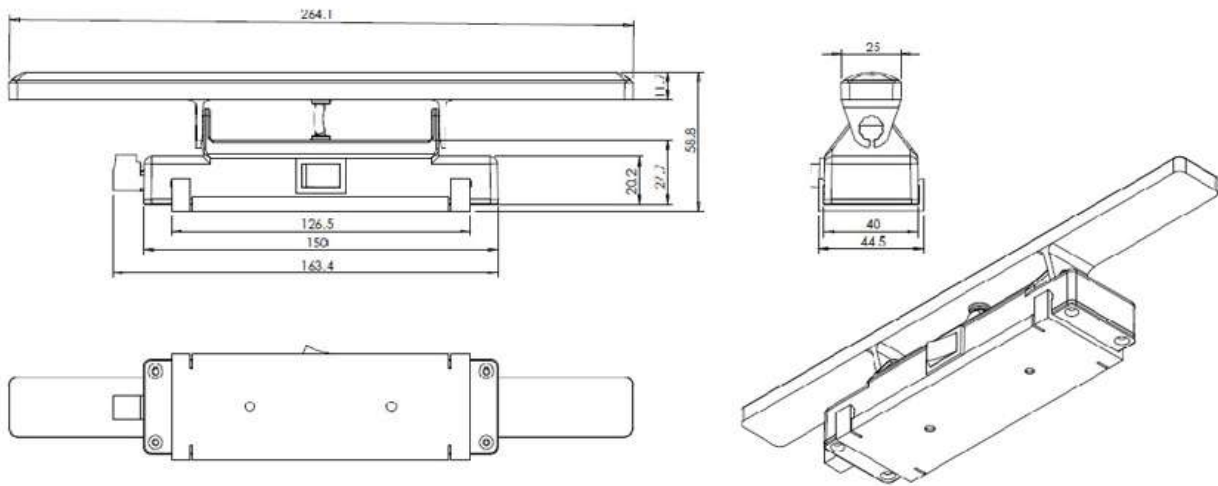

### Installation

Installation: first fix the fixed plate on the position that the lamp need to be install , and then push the lamp into the fixed plate to complete the installation.

Remove: use a screwdriver to remove 4 bayonet from the slot of the fixed plate, and then extract the lamp to complete the disassembly.

Fixed screw: Slotted countersunk flat head screws (common head style), M4\*8, ISO 2009

The following drawing specify a fixed plate size , please use this drawing to design the mounting hole.

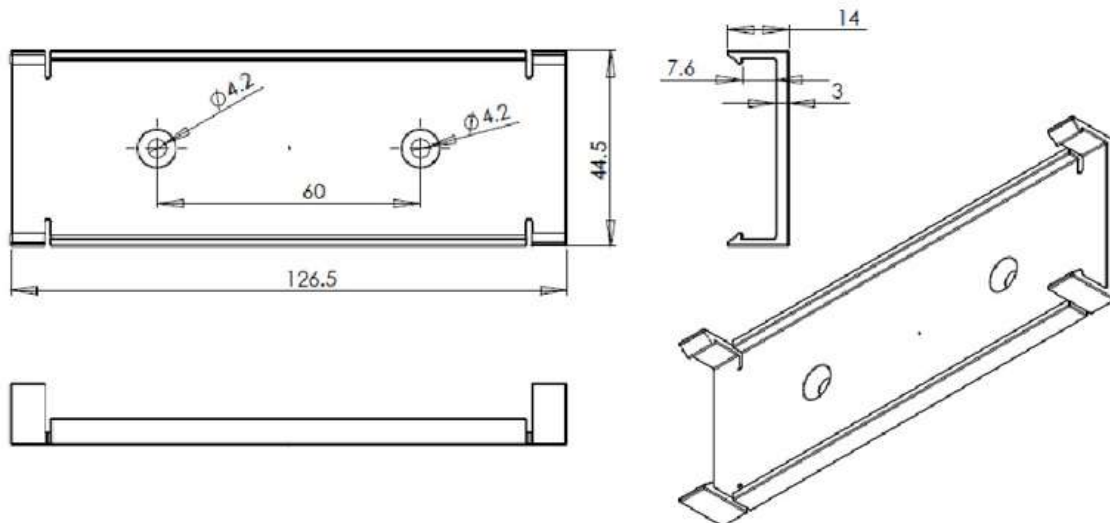

# KCL250-5/KCL400-5 LED Emergency Light for Switchgear Manuals



Product Name: LED Emergency light for Switchgear, Input Voltage: USB5V  
Product Code: KCL250-5 (250mm)  
KCL400-5 (400mm)

#### Product Features:

1. Adopting the technology of P.I.R infrared motion and photosensitive sensor.
2. Mounting: Magnetic fixing, or with screws
3. Power: Charging by USB5V or 220V power.
4. Using new type LED light source, with the performance of high brightness, low attenuation, long lifetime up to 3000h and high reliability.

#### Instruction for Switches :

Switch on: Long press switch for 2 seconds

Switch off: Long press switch for 2 seconds

1<sup>st</sup> Gear: switch off, the default mode for the light

2<sup>nd</sup> Gear: constant light , the light on state

(Adjusting method: Long press 2 seconds in 1<sup>st</sup> gear state)

3<sup>rd</sup> Gear: induction power -saving mode(40% brightness)

(Adjusting method: Press ON-OFF switch in 2<sup>nd</sup> gear state)

4<sup>th</sup> Gear: induction mode(100% brightness)

(Adjusting method: Press ON-OFF switch in 3<sup>rd</sup> gear state, the green indicator light automatically on.)

Note: the 3<sup>rd</sup> Gear and 4<sup>th</sup> gear requires the ambient brightness less than 3LUX, the distance between the light and human within 3m, then get lighting automatically, and turns off with 20s delay after leaving..

#### Operation Time:

2<sup>nd</sup> gear: 5 continuous working hours

3<sup>rd</sup> gear: constant light state, 12.5 continuous working hours, the actual working time depends on the lighting time.

4<sup>th</sup> gear: constant light state, 5 continuous working hours, the actual working time depends on the lighting time.

(All above working time should be calculated in the full charging state)

#### Charging instructions:

In-Charge: Blue indicator light on

Full-Charge: Red indicator light on

Charging time: approximately 4-6 hours

Dimension diagram

KCL250-5

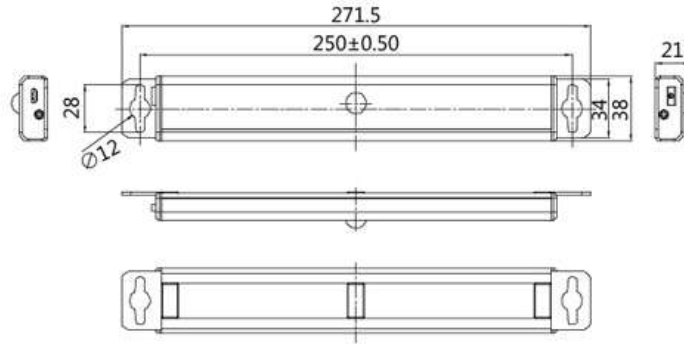

KCL400-5

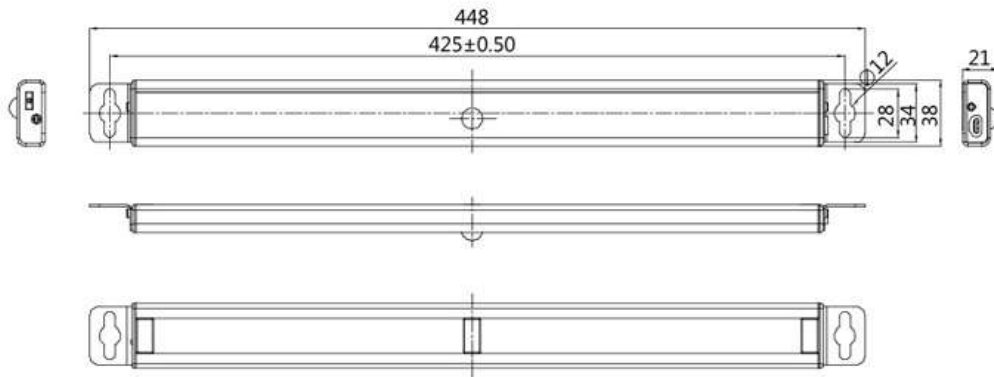

Drawings for products:

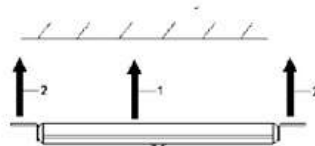
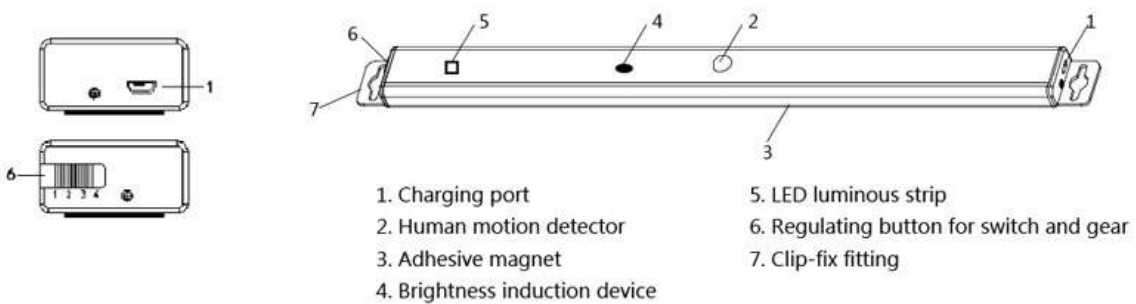

Mounting instruction:  
 1. Magnetic fixing  
 2. Screw mounting

Warnings

Don't install the light in the area with moisture , high temperature or venting air to ensure the normal use.  
 Charging timely once the light dimming to ensure the normal use of the lithium battery.  
 Don't charge more than six hours.

# LK 025 Energy-saving light



- Wide voltage range
- Integrated power unit
- Long-lived, maintenance-free
- Energy-saving by LED technology
- Daisy chain
- Magnet or screw fixing
- Quick connection

The lamp series LK 025 is suitable for all types of panels and enclosures, especially where space is at a premium. The lamps have a very long service life thanks to the use of LED technology. They are available with powerful non-slip rubberized magnets allowing them to be quickly positioned in any steel enclosure. Alternatively they can be fixed mechanically. The power output allows up to 10 lamps to be connected to each other (daisy chain). Both the power input and output connectors snap lock into their sockets. With the integrated power unit and the plugs the lamp can quickly be connected.

## Technical Drawing

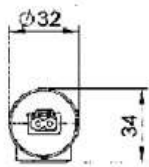

Side view  
magnet fixing

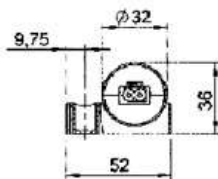

Side view  
screw fixing

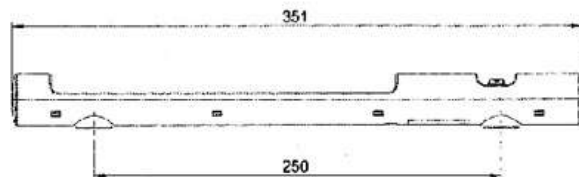

## Technical Data

Power consumption	max. 5W
Luminosity	290lm at 120°C (870lm at 360°C or equivalent 75W light bulb)
Lamp type	LED, angle of radiation 120°
Service life	Light color: daylight, color temperature: 6,500K 60,000h at 20°C (68°F)
Connection	2-pole connector with snap lock AC: max. 2.5A / 240VAC, color: white DC: max. 2.5A / 60VDC, color: blue
Mounting	magnet fixing or screw fixing, M5, 250mm centers
Casing	plastic, transparent
Dimensions	351 x 34 x 32mm (with magnet fixing) 351 x 36 x 32mm (with screw fixing)
Operating / Storage temperature	-30 to +60°C (-22 to +140°F) / -40 to +85°C (-40 to +185°F)
Operating / Storage humidity	max. 90% RH (non-condensing)
Protection type / Protection class	IP20 / II (double insulated)

Art. No. magnet fixing	Art. No. Screw fixing	Operating voltage	Switch	Weight (approx.)
02540.0-00	02540.0-01	100-240VAC, 50/60Hz (min. 90VAC, max. 265VAC)	on/off light switch	0.2kg
02540.1-00	02540.1-01	24-48VDC (min. 20VDC, max. 60VDC)	on/off light switch	0.2kg



### Application

LKL10-W Series LED light is designed for instrument cabinet illumination of various switchgear.

### Features and advantage

- ◆ Economize on energy, In the case of Illuminate effect same alike the traditional light, economizing on energy is 75% above.
- ◆ Life span is long, the LED light source, someone call it the longevity light, meaning to extinguish never. It's the solid cold light source, adopt a special electric circuit design, the life span can reach to for 100,000 hours, comparing traditional light source life span to grow 1000% above.
- ◆ The environmental protection performance is better, without ultraviolet ray and infrared rays in the spectrum, without calories and radiate, the dizzy light is small, and the castoff can recover, without pollution and do not contain the mercury chemical Element. The cold light source, can be touched, belong to typical model of the green illuminate light source.
- ◆ Special circuit design, if anyone LED is bad, it isn't without influence to normal lumination of others LED.
- ◆ Special structure design, light body position can be adjusted, that solves the problem of less lumination angle of LED.
- ◆ The power supply adapt to AC/DC110~230V,suitable in application case of switchgear especially .
- ◆ With two mounting methods of clamp and fixation.

### Technique parameters

Enclosure material	PC-ABS(halogen-free)
Protection category	IP 20
Power supply	AC(50/60Hz)/DC 110V~230V
Wire connection	1×4mm <sup>2</sup> or 2×1.5mm <sup>2</sup>
Insulating strength	AC2500V, 1Min
luminescence component	LED
Ambient temperature	-25℃~50℃
Relative humidity	25% ~ 95%
Life span	More than 100,000hours

## Models explanation

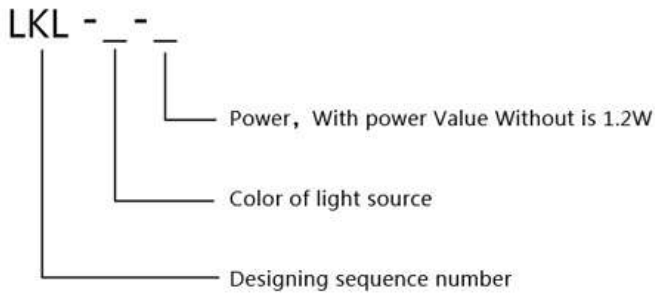

TYPE	LKL10-W	LKL10-W-3
Color of light source	White	Black
Power	1.2W	3W

## Dimension diagram

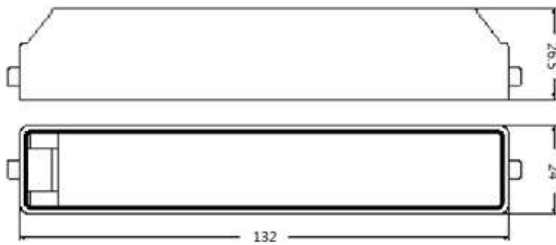

Dimension of LKL10-W light body

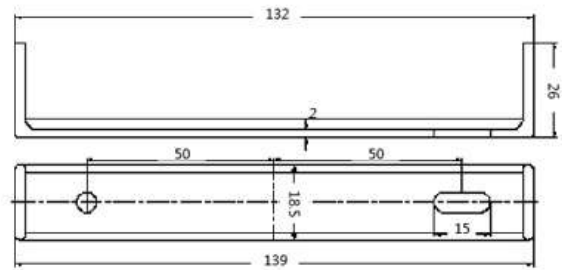

Dimension of LKL10-W light bracket

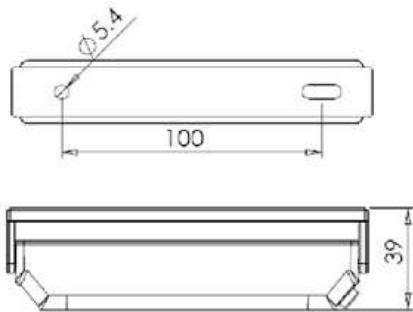

Dimension of LKL10-W-3 light body

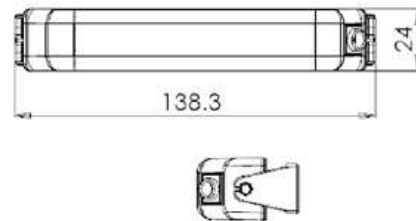

Dimension of LKL10-W-3 light bracket

## Installation

Assemble by clamp or bolt fixation. Assemble bracket first, then connect the power cable into light body terminal, insert the terminal side of light body into assemble hole of bracket, another side insert into the another side of bracket with screwdriver.

The angle between the support and the light body can be adjust according to the lumination need.

LKL10-W Light body



LKL10-W Bracket



LKL10-W assembled



### T5 Fluorescent Cabinet Lamp



- High brightness, small size, with on/off switch
- High lighting effect, save 55% power
- Long life non flicker and can start by low voltage
- T5 Fluorescent with Opal Cover, Or with Striate Cover

Model	Name	voltage	Power	PF	Dimension	Color temperature	QTY/CTN
LK-Y5Z04/YW01	T5 Aluminum Profile Fluorescent	220V/50HZ	4W	0.55	156x24x36	2700K/6500K	30
LK-Y5Z06/YW01			6W		255x24x36	2700K/6500K	30
LK-Y5Z08/YW01			8W		309x24x36	2700K/6500K	30
LK-Y5Z12/YW01			12W		486x24x36	2700K/6500K	30
LK-Y5Z14/YW01			14W	571x24x36	2700K/6500K	30	
LK-Y5Z18/YW01			18W	731x24x36	0.95	2700K/6500K	30
LK-Y5Z21/YW01			21W	871x24x36	2700K/6500K	30	

### T5 LED Cabinet Lamp



- The LED Lighting has no strobe, no infrared and ultraviolet, radiation free., Mercury free protect the natural environment
- High-quality LED chips as the illuminant, save more power, LED chip is antistatic.
- LED chips are solid encapsulation, they belong to cold light type, impact resistance, shockproof., easy for installation.
- Start fast, Long life: operation life about 50 thousand hours.

Model	LED Qty	Input voltage	Power	Luminous flux	Life (H)	Ra	External dimension	Color temperature	Qty
LK-L5X10A	96	AC110-240V	10W	870	>50000	≥80	850mm	3000/6400	30
LK-L5X10A	102	AC110-240V	10W	890	>50000	≥80	871mm	3000/6400	30
LK-L5X9A	80	AC110-240V	9W	700	>50000	≥80	731mm	3000/6400	30
LK-L5X6A	60	AC110-240V	6W	530	>50000	≥80	550mm	3000/6400	30
LK-L5X6A	64	AC110-240V	6W	560	>50000	≥80	571mm	3000/6400	30
LK-L5X5A	52	AC110-240V	5W	450	>50000	≥80	486mm	3000/6400	30
LK-L5X4A	38	AC110-240V	4W	330	>50000	≥80	309mm	3000/6400	30



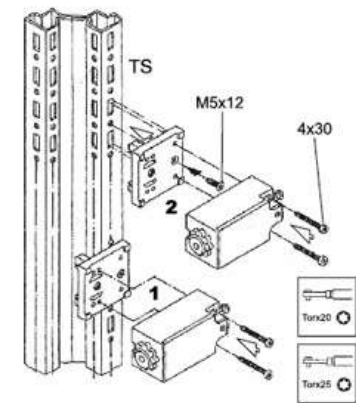
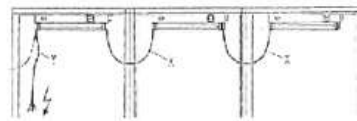
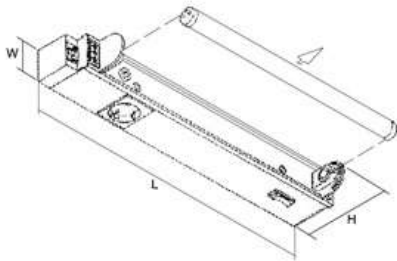
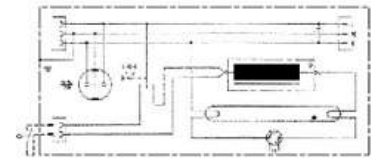
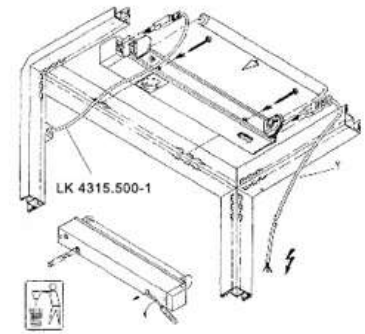

	Type	Type
	<b>LK-4138.10-1</b>	<b>LK-4138.18-1</b>
L mm	425	685
W mm	50	50
H mm	117	117
Pw	10w	18w

X	Y
LK4315.200-1	LK4315.100-1
LK4315.400-1	
LK4315.600-1	

## Lamp Cable



Door-Control Switch



Connection Cable



Power Cable

Type	LK4315.500-1
Cable length(mm)	500
Colour	White

Type	LK4315.200-1	LK4315.600-1	LK4315.4000-1
Cable length(mm)	1000	600	4000
Colour	Orange	Orange	Orange

Type	LK4315.100-3	LK4315.100-2	LK4315.100-1
Cable length(mm)	3000	2000	1000
Colour	Orange	Orange	Orange



### Features

- ◆ Economic thermoplastic
- ◆ Stainless steel roller, punch, and Spring
- ◆ Max. ±95° rotary lever
- ◆ Cable gland size M20\*1.5

### Contact configurations

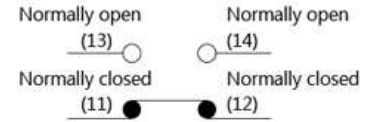

### Dimensions:

PLS-131 (Thermoplastic roller available)

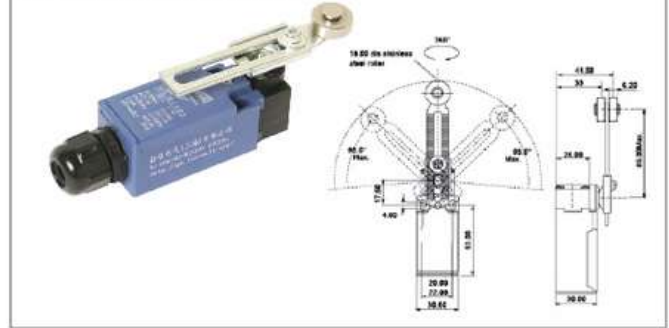

PLS-103

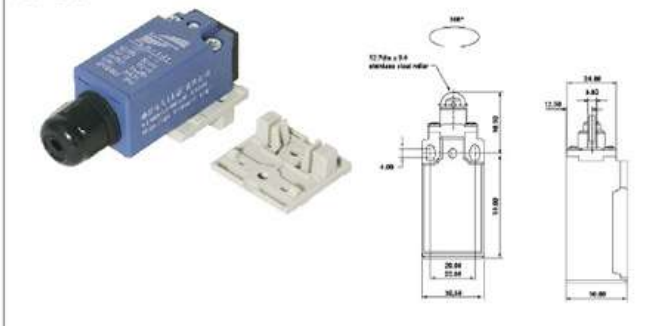

PLS-101

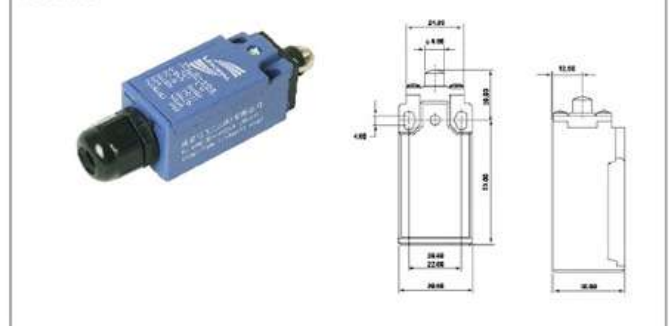

### Ratings

Rated voltage	Non-inductive load (A)				Inductive load (A)			
	Resistive load		Lamp load		Inductive load		Motor load	
	NC	NO	NC	NO	NC	NO	NC	NO
125VAC	5	5	1.5	0.7	3	3	2	1
250VAC	5	5	1	0.5	3	3	1.5	0.8
8VDC	5	5	3	3	5	4	3	3
14VDC	5	5	3	3	4	4	3	3
30VDC	5	5	3	3	4	4	3	3
125VDC	0.4	0.4						
250VDC	0.2	0.2						

Inrush current N.C.:24A max., N.O.:12A max.

- Note:
1. Inductive loads have a power factor of 0.4 min. (AC) and a time constant of 7 msec max. (DC).
  2. Lamp loads have an inrush current of 10 times the steady-state current. Motor loads have an inrush current of 6 times the steady-state current.
  3. For the products with spring, the operating range is limited to the part from the front of the spring to the 1/3 full length of the spring.

### Specification

Code	PLS	101 301	103 303	111 311	121 321	127 327	131 331	161 361	171 371	181 381	191 391
Operating force	OF(Max.)	700g	700g	700g	500g	700g	500g-cm	100g	100g	100g	500g-cm
Release force	RF(Min.)	200g	200g	200g	100g-cm	200g	100g-cm	40g	40g	40g	100g-cm
Pre-Travel	PT(Max.)	1.8mm	1.8mm	1.8mm	20°	1.8mm	20°	30mm	30mm	30mm	20°
Tripping position	TP±10%	2.0mm	2.0mm	2.0mm	22.5°	2.0mm	22.5°	22.5°	22.5°	22.5°	22.5°
Movement differential	MD(Max.)	1.2mm	1.2mm	1.2mm	10°	1.2mm	10°	14°	14°	14°	10°
After travel	OT(Min.)	4.0mm	4.0mm	4.0mm	75°	4.0mm	75°	20mm	20mm	20mm	75°
Total travel	TT(Min.)	5.8mm	5.8mm	5.8mm	95°	5.8mm	95°	50mm	50mm	50mm	95°
Angle of rotary lever					22.5°		22.5°				22.5°

### Characteristics

Operating speed	0.1 mm/s to 50cm/s (in case of pin plunger)
Operating frequency	Mechanical: 120 operations/ min Electronic: 30 operations/ min
Contact Resistance	25mΩ (mm) (Initial)
Insulation resistance	100mΩ Min. at 500VDC
Dielectric strength	1000VAC, 50/60Hz/ 1 min between terminals of same polarity
	1500VAC, 50/60Hz/ 1 min between current-carrying metal parts and ground
Vibration resistance	1500VAC, 50/60Hz/ 1 min between each terminal and non-current-carrying metal part
	10-55 Hz, 1.5mm double amplitude
Shock resistance	Mechanical durability: 1,000m/Sec <sup>2</sup> (approx.100G <sup>2</sup> S)
	False action durability: 300m/Sec <sup>2</sup> (approx.30G <sup>2</sup> S)
Ambient operating temperature	Operating -10 ~+ 70°C (no icing)
Ambient operating Humidity	95%RH Max
Service life	Mechanical > 10,000,000 operations, Electrical > 500,000 operations
Degree of protection	IP65 (IEC standard)

## LK-705

Sealed enclosures when subject to external temperature fluctuations develop pressure differential toward the ambient. As a consequence entrance of dust and/or humidity is likely to happen through leakage points. Installing a LK-705 prevents this risk while preserving a high protection degree for the enclosure.

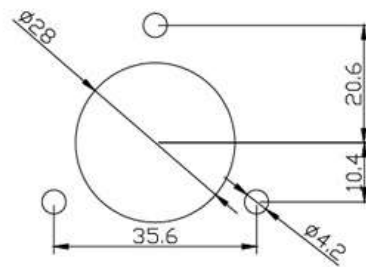

Features	unit	Characters
Material	-	ABS self-extinguishing
Color	-	Grey(RAL7035), Black(RAL9005)
Protection degree	-	IP54
Fixing	-	Screws with rubber gasket
Dimensions HxWxD	mm	70x50x21
Weight	kg	0.03

## Documents Pocket WJ-1

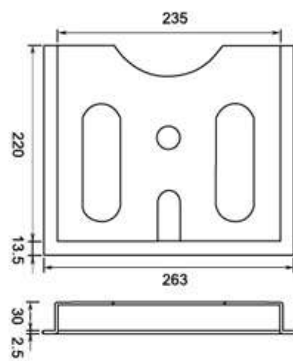

Plastic Documents Pockets  
For affixing to the inside surfaces of panel doors

Material :  
plastic ABS with self-adhesive fastening strips  
3M adhesive tape

Installation:  
Screw mounting or adhesive tape mounting

Colour:  
Similar to RAL7035

## Documents Pocket WJ-2

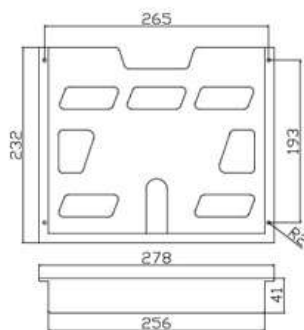

## Documents Pocket WJ-3

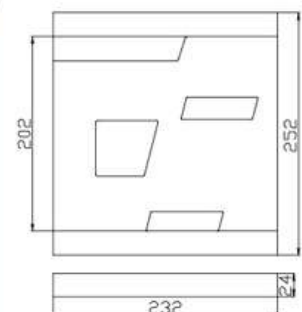

## Documents Pocket WJ-4

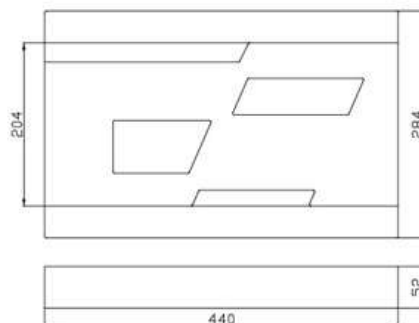

## Product back

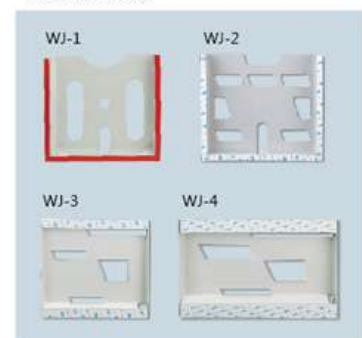

2018~2019



**LINKWELL**  
LINKWELL

Email: [info@linkwell.org](mailto:info@linkwell.org)

Web: [www.linkwell.org](http://www.linkwell.org), [www.cnlinkwell.com](http://www.cnlinkwell.com)